

Moving solutions with safety, reliability and efficiency

PLANNING GUIDE



www.hyundaielevator.co.kr

Contents

03 Selection Of Elevator System

Elevators Layout Plan

- 1. Passanger Elevators
 - 04 Machine-Room-Less(MRL) Type
 - 06 General Traction Type(Geared / Gearless Type)
 - 08 General Traction Type(150~600m/min)
 - 10 Hydraulic Indirect Type
 - 2. Observation Elevators
 - 11 1-Side / 2-Side Observation Type
 - 12 3-Side Observation Type
 - 13 Semicircle Observation Type
 - 3. Freight Elevators
 - 14 General Traction Type
 - 4. Automobile Elevators
 - 16 General Traction Type
 - 17 Hydraulic Indirect Type
 - 5. Hospital Bed Elevators
 - 18 General Traction Type
 - 19 6. Typical Entrance Layouts
-

Works To Be Done By Other Contractors

- 23 1. Building Work / Electrical Work
 - 24 2. Electric Power Requirements (By Others)
-

Escalators / Moving Walks Layout Plan

- 26 1. Worldclass Escalators 30° / 35°
 - 28 2. Modular Escalators
 - 29 3. H-Series Escalators
 - 30 4. Moving Walks
-

Works To Be Done By Other Contractors

- 31 1. Electric Power Requirements (By Others)
-



SELECTION OF ELEVATOR SYSTEM

The selection of elevators should be made in consideration of the building type/scale, tenant characteristics, elevator usage and the anticipated passenger carrying capacity at the building's traffic peak time.

Hyundai elevators are available from hydraulic elevators to low-medium and high-speed traction elevators, covering the full range of vertical transportation requirements.

And a variety of functional and attractive designs per usages, such as passenger, service, observation, hospital bed, freight and automobile elevators are offered for architects' and customers' flexible applications.

KINDS OF BUILDING	USAGE	CONTROL & SPEED (m/min)	OPERATION
Low-Rise Apartment Low-Rise Building	Passenger Observation Hospital	Machine-Room-Less 45, 60 General Traction 60 Hydraulic 30, 45	1 Car : Selective Collective 2 Cars : Duplex Selective Collective
Mid-Rise Apartment Mid-Rise Building	Passenger Observation Hospital	Machine-Room-Less 60, 90, 105 General Traction 60, 90, 105	3-8 Cars : Group Supervisory
High-Rise Apartment High-Rise Building	Passenger	Machine-Room-Less 120 General Traction 150 ~ 600	1 Car : Selective Collective 2 Cars : Duplex Selective Collective 3-8 Cars : Group Supervisory
Parking Building	Automobile	General Traction 30, 45, 60 Hydraulic 20, 30, 45	Single Automatic
Factory, Warehouse	Freight	General Traction 30, 45, 60 Hydraulic 20, 30, 45	Single Automatic 1 Car : Selective Collective 2 Cars : Duplex Selective Collective

Note : The table shows the common method of elevator system selection per usages.

Code Application of Elevator Models

□ — □ — □ — □ — □ **F/** □ **ST**

Capacity
(Persons/kgs)

Speed
(m/min)

No. of Install. Floors
(Including Non-Stop Floors)

No. of Stop
Floors

Usage				Door Opening Type		
MRL	General Traction	Hydraulic	Type	Single Entrance	Double Entrance	Type
MP	P	HP	Passenger	CO	COD	2-Panel Center Opening
MS	S	HS	Service	2S	2SD	2-Panel Side Opening
MPF	(PF)	(HPF)	(Passenger & Freight)	2CO	2COD	4-Panel Center Opening
MOB	OB	HOB	Observation	2U	2UD	2-Panel Up-Sliding
MB	B	HB	Hospital Bed	3S	3SD	3-Panel Side Opening
MF	F	HF	Freight	3U	3UD	3-Panel Up-Sliding
MA	A	HA	Automobile			

Note : MRL(Machine-Room-Less)

Passenger Elevators

Machine-Room-Less(MRL) Type 60~105m/min

user(Permanent Magnet Synchronous Motor)

Plan of Hoistway & Machine Room (8~17 Person)

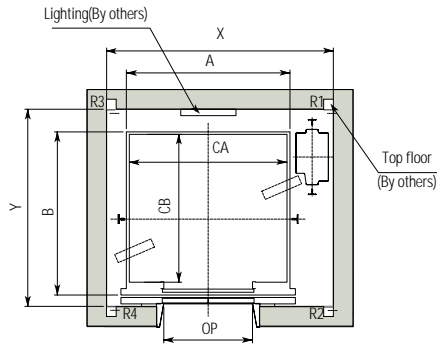

Floor without control panel

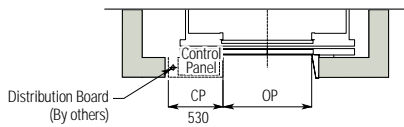

Floor with control panel

Note : The lighting of hoistway should be installed less than 500 mm from above the ceiling of hoistway and within 500 mm above the bottom of the pit. (By others)

Section of Hoistway

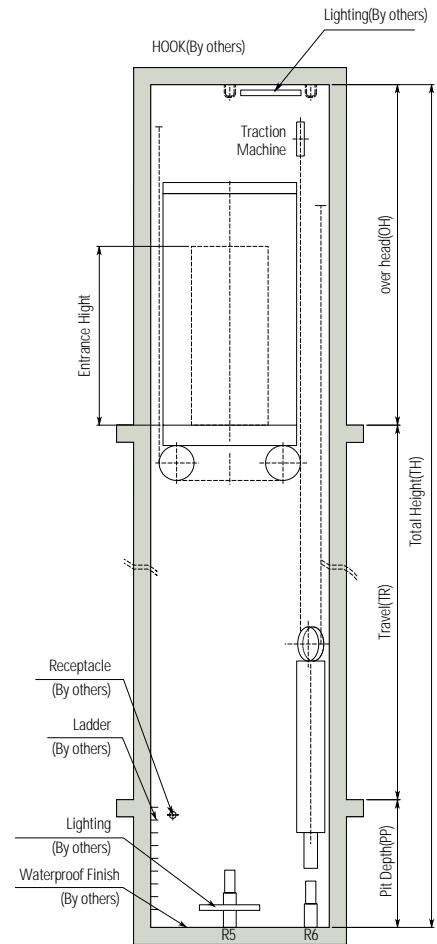

Plan of Hoistway & Machine Room (20, 24 Person)

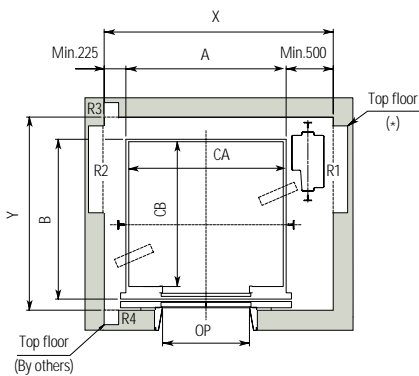

Floor without control panel

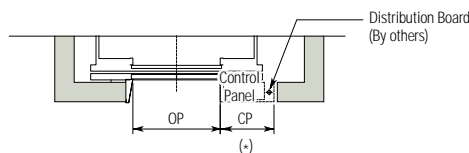

Floor with control panel

Standard Dimensions (8~17 Person) (Unit : mm)

Speed (m/min)	Capacity		Clear Opening OP	Car		Hoistway		Moter (kW)
	Persons	kg		Internal CA × CB	External A × B	1 Car X	Depth Y	
60	8	550	800	1300 × 1100	1360 × 1255	2050	1700	3.4
90								5.1
105								5.9
60	9	600	800	1300 × 1190	1360 × 1345	2050	1800	3.7
90								5.6
105								6.5
60	10	700	800	1300 × 1300	1360 × 1455	2050	1800	4.3
90								6.5
105								7.5
60	11	750	800	1300 × 1400	1360 × 1555	2050	1850	4.6
90								6.9
105								8.1
60	13	900	900	1600 × 1300	1660 × 1455	2300	1800	5.6
90				1500 × 1400	1560 × 1555	2200	1850	8.3
105								9.7
60	15	1000	900	1600 × 1400	1660 × 1555	2300	1900 (2100)	6.2
90								9.2
105								10.8
60	17	1150	1000	1800 × 1400	1900 × 1570	2600	2100	7.1
90								10.6
105								12.4

- Notes :**
1. The dimension in () is for the heavy car weight such as the car floor using finished granite.
 2. When non-standard capacities and dimensions (including fire protection doors) are required to meet the local code, please consult Hyundai.
 3. The minimum hoistway dimensions are shown on the above table. Therefore, some allowances should be made considering the sloping of the hoistways.
 4. In case of elevator for disable, the dimension of CA is more than 1100 mm, CB more than 1350 mm.
 5. If the height of hoistway is over 11 m, please consult Hyundai as to the needs for emergency exit.
 6. Above dimensions are applied to standard door only. In case fire protection door is applied, hoistway size for 1 car should be applied above X1 dimensions plus 100 mm and over.

Standard Dimensions (20, 24 Person) (Unit : mm)

Speed (m/min)	Capacity		Clear opening OP	Car		Hoistway		Moter (kW)
	Person	kg		Internal CA × CB	External A × B	1 Car X	Depth Y	
60	20	1350	1000	1800 × 1600	1900 × 1770	2625	2400	9
90								13
105								15
60	24	1600	1100	2000 × 1700	2100 × 1870	2825	2450	10.7
90								16
105								18

- Notes :**
1. When non-standard capacities and dimensions are required to meet the local code, please consult Hyundai.
 2. The minimum hoistway dimensions are shown on the above table. Therefore, some allowances should be made considering the sloping of the hoistways.
 3. Consult Hyundai if the emergency stop device is installed on the counterweight.

Reactions (Unit : mm)

Persons	M/C Room Reaction(kg)				Pit Reaction(kg)			
	R1	R2	R3	R4	R5		R6	
					Speed (m/min)		Speed (m/min)	
8~17	8000	3500	1500	3000	Under 60	10000	Under 60	8000
					90.105	14000	90.105	12000
20, 24	14000	3800	1500	4500	Under 60	12000	Under 60	9500
					90.105	21500	90.105	17500

- Notes :**
1. The minimum dimensions for the standard are shown on the above table. Consult Hyundai in case of non-standard.
 2. Consult Hyundai if the hoistway is steel structure.

Persons	Speed (m/min)	Overhead (OH)	Pit (PP)	Control panel (CP)(→)
8-17	45,60	3800	8-15 : 1500 17 : 1600	530
	90	3900	1800	
	105	4000	2100	
20, 24	60	4200	1500	530
	90	4350	1800	630
	105	4450	2100	630

- Notes :**
1. Above dimensions are applied for car height of 2500 mm. (car internal height is 2300 mm). For other applicable dimensions, consult Hyundai.
 2. For car internal height (under 17 persons) of 2500 mm, dimension of overhead is OH plus 200mm.
 3. If the dimension between the wall of hoistway and car external dimensions (A, B) is in excess of over 850 mm, the dimension of overhead is OH plus 200mm.
 4. The minimum hoistway dimensions are shown on the above table. Therefore, some allowances should be made considering the sloping of the hoistways.
 5. When face to face arrangement is required, partitioning work for hoistway is required.
 6. If the hoistway is glass, consult Hyundai as it needs to finish joining glass.
 7. The lighting should be installed at the top and bottom of hoistway.

Passenger Elevators

General Traction Type 45~120m/min (Geared/Gearless Type)

• Refer to page 7 for the gearless type.

Plan of Hoistway & Machine Room

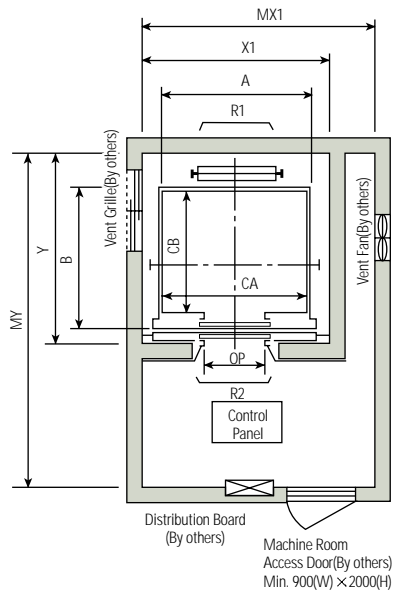

Note : Machine room temperature should be maintained below 40 °C with ventilating fan and/or air conditioner(if necessary)and humidity below 90%.

Section of Hoistway

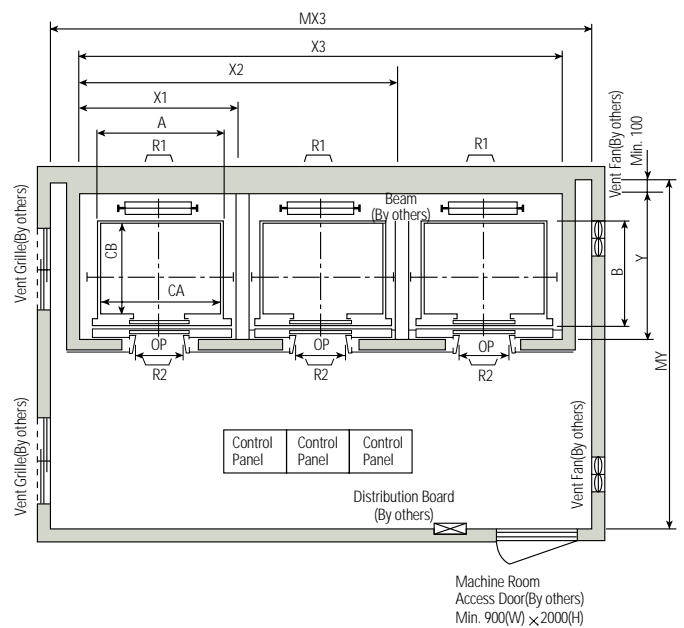
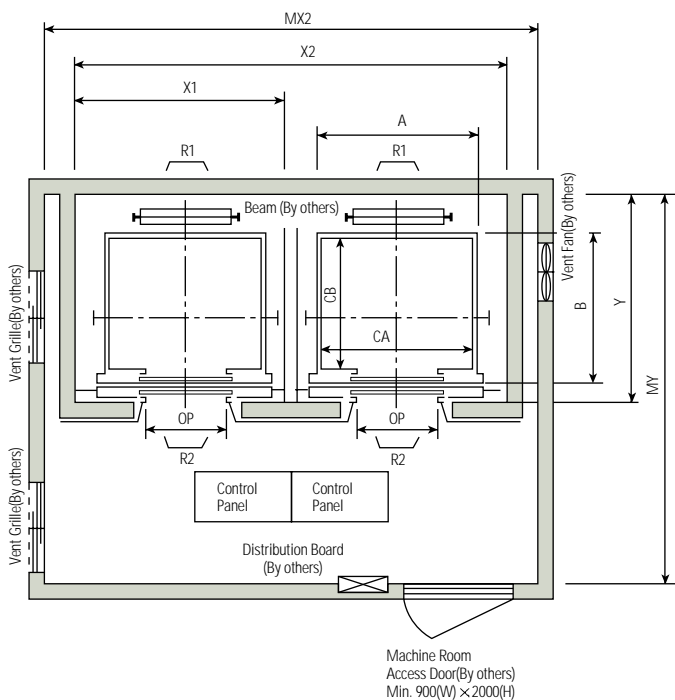
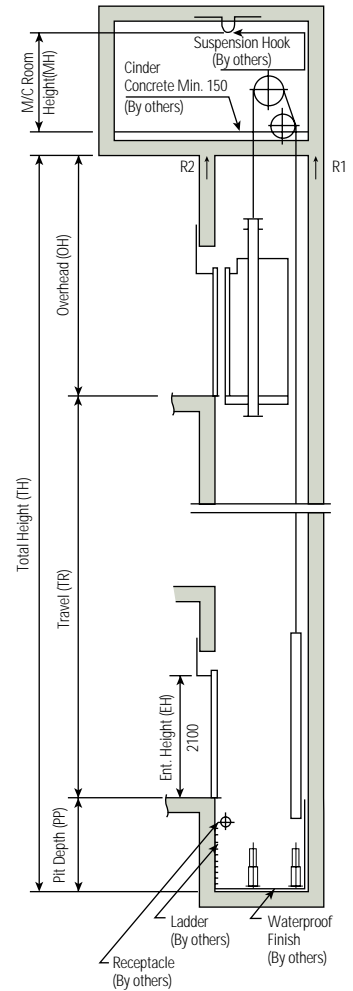

Standard Dimensions & Reactions

(Unit : mm)

Speed (m/min)	Capacity		Clear Opening OP	Car		Hoistway				M/C Room				M/C Room Reaction(kg)	
				Internal	External	1Car	2Cars	3Cars	Depth	1Car	2Cars	3Cars	Depth		
	Persons	kg		CA × CB	A × B	X1	X2	X3	Y	MX1	MX2	MX3	MY	R1	R2
45	6	450	800	1400 × 850	1460 × 1005	1800	3700	5600	1430	2000	4000	6000	3200	3600	2000
	8	550	800	1400 × 1030	1460 × 1185	1800	3700	5600	1610	2000	4000	6000	3400	4050	2250
	9	600	800	1400 × 1100	1460 × 1255	1800	3700	5600	1680	2000	4000	6000	3500	4100	2450
				1400 × 1150	1460 × 1305	1800	3700	5600	1780	2000	4000	6000	3550		
	10	700	800	1400 × 1250	1460 × 1405	1800	3700	5600	1830	2000	4000	6000	3600	4200	2700
11	750	800	1400 × 1350	1460 × 1505	1800	3700	5600	1930	2000	4000	6000	3700	4550	2800	
60	13	900	900	1600 × 1350	1660 × 1505	2050	4200	6350	1980	2300	4400	6800	3750	5100	3750
				1600 × 1400	1660 × 1555	2050	4200	6350	2050	2300	4400	6800	3800		
90	15	1000	900	1600 × 1500	1660 × 1655	2050	4200	6350	2130	2300	4400	6800	3850	5450	4300
				1600 × 1550	1660 × 1705	2050	4200	6350	2200	2300	4400	6800	3900		
	17	1150	1000	1800 × 1500	1900 × 1670	2350	4800	7250	2180	2600	4900	7500	3900	6600	5100
1100	2000 × 1350	2100 × 1520	2550	5200	7850	2030	2800	5250	8300	3800					
105	20	1350	1000	1800 × 1700	1900 × 1870	2350	4800	7250	2380	2600	4900	7500	4200	7800	6000
				1800 × 1730	1900 × 1900	2350	4800	7250	2510	2600	4900	7500	4300		
				1100	2000 × 1500	2100 × 1670	2550	5200	7850	2180	2800	5250	8300		
120	24	1600	1100	2000 × 1550	2100 × 1720	2550	5200	7850	2330	2800	5250	8300	4100	8500	6800
				2000 × 1750	2100 × 1920	2550	5200	7850	2430	2900	5400	8300	4300		
				2000 × 1800	2100 × 1970	2550	5200	7850	2580	2900	5400	8300	4400		
				2150 × 1600	2250 × 1770	2700	5500	8300	2280	3000	5650	8700	4200		
2150 × 1670	2250 × 1840	2700	5500	8300	2450	3000	5650	8700	4300						

- Notes :**
- Above hoistway dimensions are based on 15-storied buildings. For application to over 16-storied buildings, the hoistway dimensions shall be at least 5% larger considering the sloping of the hoistways.
 - Above dimensions are based on center opening doors. For applicable dimensions with side opening doors, consult Hyundai.
 - When non-standard capacities and dimensions are required to meet the local code, consult Hyundai.
 - The capacity in persons is calculated at 68kg/person. (EN81 75kg/person)
 - Above dimensions are applied in case the door is standard. In case fire protection door is applied, hoistway size for 1 car should be applied above X1 dimension plus 100mm.

(Unit : mm)

Gearless Type(Optional)

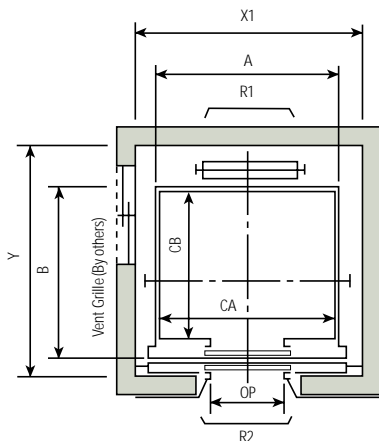

Speed (m/min)	Overhead (OH)	Pit (PP)	M/C Room Height (MH)
45	4400	1200	2200
60	4600	1500	2200
90	4800	1800	2400
105	5000	2100	2400
120	5000	2100	2600

Note : Above is minimum size.

Passenger Elevators

General Traction Type 150~600m/min

Plan of Hoistway & Machine Room (In-Line Arrangement of 3 Units)

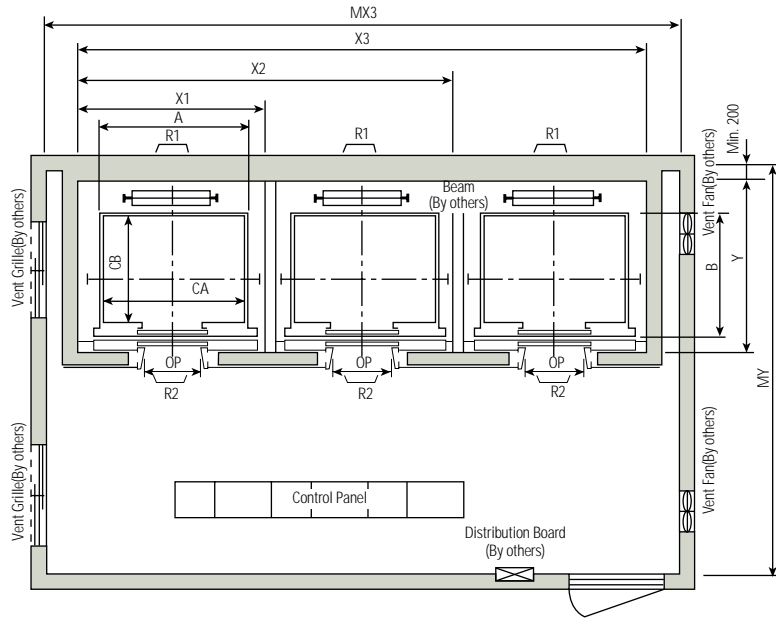

Note: Machine room temperature should be maintained below 40°C with ventilating fan and/or air conditioner (if necessary) and humidity below 90%. Toxic gas or dust should not be generated.

Machine Room
Access Door (By others)
Min. 900(W) x 2000(H)

Section of Hoistway

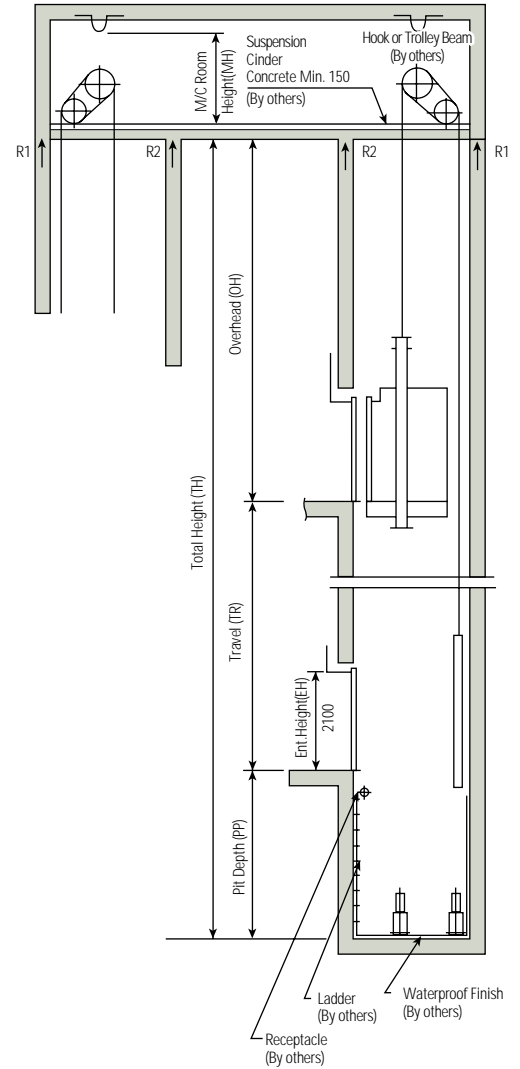

Face-to-Face Arrangement

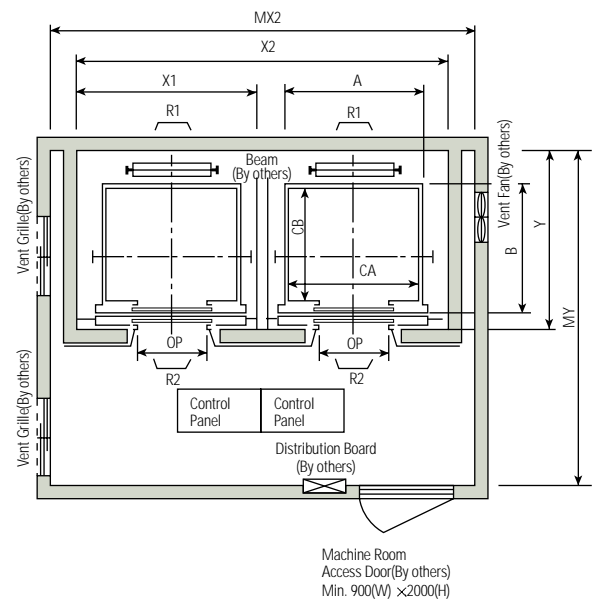
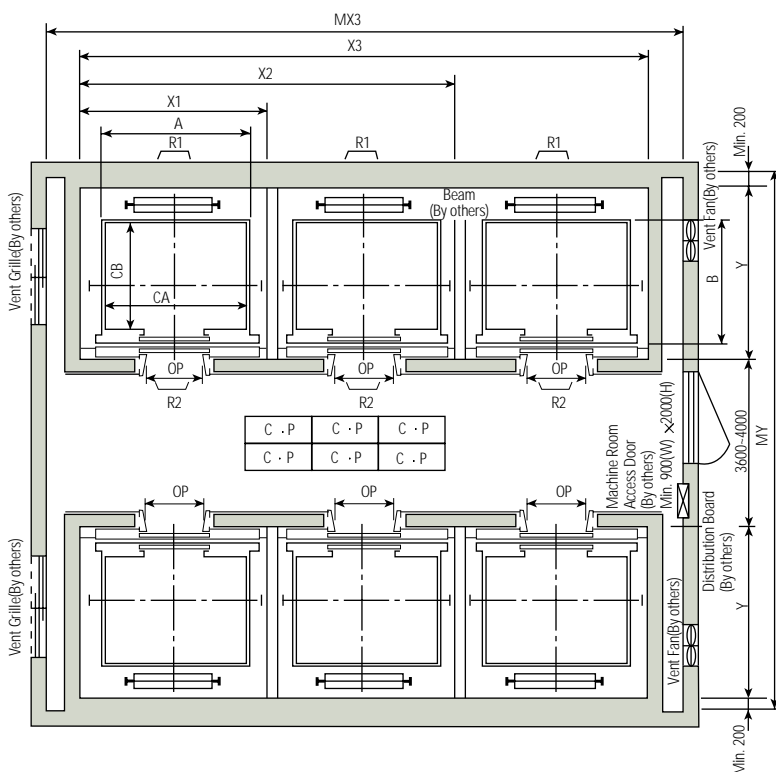

Standard Dimensions & Reactions

(Unit : mm)

Speed (m/min)	Capacity		Clear Opening	Car		Hoistway				M/C Room				M/C Room Reaction(kg)			
				Internal	External	1Car	2Cars	3Cars	Depth	1Car	2Cars	3Cars	Depth				
	Persons	kg	OP	CA × CB	A × B	X1	X2	X3	Y	MX1	MX2	MX3	MY	R1	R2		
150	13	900	900	1600 × 1350	1700 × 1570	2300	4550	6900	2200	2800	5500	7900	4500	12030	6630		
				1600 × 1400	1700 × 1620	2300	4550	6900	2250	2800	5500	7900	4500				
	15	1000	900	1600 × 1500	1700 × 1720	2300	4550	6900	2350	2800	5500	7900	4700	12810	6950		
				1600 × 1550	1700 × 1770	2300	4550	6900	2400	2800	5500	7900	4700				
	180	17	1150	1000	1800 × 1500	1900 × 1720	2500	4950	7500	2400	3000	6100	8800	4700	13080	7130	
				1100	2000 × 1350	2100 × 1570	2700	5350	8100	2250	3200	6250	9100	4500			
20		1350	1000	1800 × 1700	1900 × 1920	2500	4950	7500	2600	3000	6100	8900	5000	14360	7650		
				1800 × 1730	1900 × 1950	2500	4950	7500	2630	3000	6100	8900	5000				
				1100	2000 × 1500	2100 × 1720	2700	5350	8100	2400	3200	6250	9100			4700	
					2000 × 1550	2100 × 1770	2700	5350	8100	2450	3200	6250	9100			4700	
24	1600	1100	2000 × 1750	2100 × 1970	2700	5350	8100	2650	3200	6250	9100	5000	15090	8080			
			2000 × 1800	2100 × 2020	2700	5350	8100	2700	3200	6250	9100	5000					
			2150 × 1600	2250 × 1820	2850	5650	8550	2500	3400	6500	9400	4900					
			2150 × 1670	2250 × 1890	2850	5650	8550	2570	3400	6500	9500	4900					
210	15	1000	900	1600 × 1500	1700 × 1720		4600	6950	2400		5600	8200	4900	12810	7800		
				1600 × 1550	1700 × 1770		4600	6950	2450		5600	8200	4900				
			1000	1800 × 1300	1900 × 1520		5000	7550	2200		5800	8400	4900				
	17	1150	1000	1800 × 1370	1900 × 1590		5000	7550	2300		5800	8400	4900	14100	8000		
				1000	1800 × 1500	1900 × 1720		5000	7550	2400		6100	8900			4900	
				1100	2000 × 1350	2100 × 1570		5400	8150	2250		6200	9000			4900	
240	20	1350	1000	1800 × 1700	1900 × 1920		5000	7550	2600		6100	8800	5000	15100	8050		
				1800 × 1730	1900 × 1950		5000	7550	2650		6100	8800	5000				
			1100	2000 × 1500	2100 × 1720		5400	8150	2400		6200	9000	5000				
	24	1600	1100	2000 × 1550	2100 × 1770		5400	8150	2450		6200	9000	5000	15700	8100		
				2000 × 1750	2100 × 1970		5400	8150	2650		6400	9000	5000				
				2000 × 1800	2100 × 2020		5400	8150	2700		6400	9000	5000				
2150 × 1600				2250 × 1820		5700	8650	2500		6500	9400	5000					
300	20	1350	1000	1800 × 1700	1900 × 1920		5100	7700	2650		6200	9100	6000	17800	13200		
				1800 × 1730	1900 × 1950		5100	7700	2700		6200	9100	6300				
			1100	2000 × 1500	2100 × 1720		5500	8300	2450		6200	9100	5900				
	360	24	1600	1100	2000 × 1550	2100 × 1770		5500	8300	2500		6200	9100	6300	18100	13500	
					2000 × 1750	2100 × 1970		5500	8300	2650		6500	9100	6300			
					2000 × 1800	2100 × 2020		5500	8300	2700		6500	9100	6300			
2150 × 1600					2250 × 1820		5800	8750	2500		6500	9400	6200				
420	17	1150	1000	2150 × 1670	2250 × 1890		5800	8750	2600		6500	9400	6300				
				1800 × 1500													
				2000 × 1500													
480	20	1350	1100	2000 × 1500													
				2000 × 1500													
540	24	1600	1100	2000 × 1500													
				2000 × 1500													
600	24	1600	1100	2000 × 1750													

- Notes :**
1. The minimum hoistway dimensions are shown on the above table. Therefore, some allowances should be made considering the sloping of the hoistways.
 2. Above dimensions are based on center opening doors. For applicable dimensions with side opening doors, consult Hyundai.
 3. For elevators with more than 28 persons capacity, consult Hyundai.
 4. When non-standard capacities and dimensions are required to meet the local code, consult Hyundai.
 5. The capacity in persons is calculated at 68kg/person. (EN81 75kg/person)
 6. Above dimensions are applied in case the door is standard. In case fire protection door is applied, hoistway size for 1 car should be applied above X1 dimension plus 100 mm and over.

(Unit : mm)

Speed (m/min)	Overhead (OH)	Top Clearance (TC)	Pit (PP)	M/C Room Height (MH)
150	5700	2000	2400	2400
180	6000	2300	2700	2500
210	6400	2700	3200	2800
240	7100	3350	3850	2800
300	7700	4000	4050	3000

(Unit : mm)

Speed (m/min)	Overhead (OH)	Top Clearance (TC)	Pit (PP)	M/C Room Height (MH)
360	7700	4000	4050	3000
420	9500/8400	6000/4900	5600/4500	3200
480	9500	6000	6000	3500
540	9750	6250	8000	3500
600	9750	6250	8000	3500

- Notes :**
1. The above table shows minimum figures. Therefore, some allowances should be made considering errors that may occur during construction.
 2. Above dimensions are applied in case car height is 2500 mm. In case car height is 2500 mm and over, overhead should be applied above dimension plus additional height.

Passenger Elevators

Hydraulic Indirect Type

Plan of Hoistway & Machine Room

Fork Type (400~1000kg)

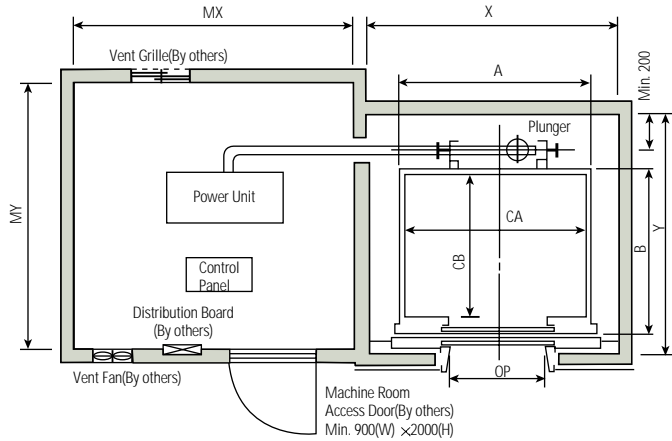

Underslung Type (1150~1600kg)

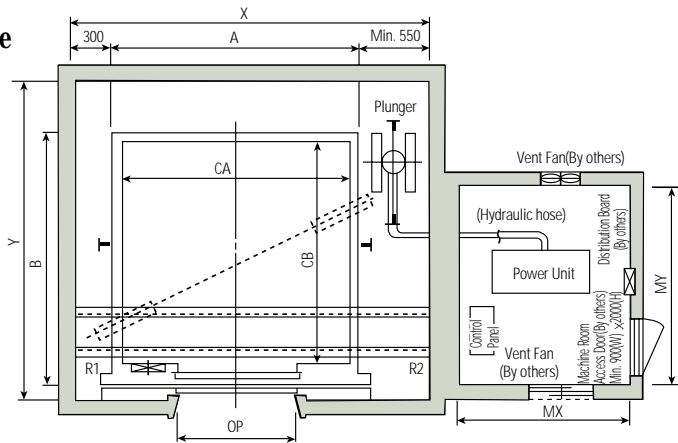

(Unit : mm)

Speed (m/min)	Persons	Overhead (OH)	Pit (PP)	M/C Room Height (MH)	Travel (TR)
30, 45	6~15	3900	1200	2000	20m
	17~24	4500			

- Notes : 1. Above is minimum size.
2. Consult Hyundai if the travel height is 20m and over.
3. Machine room temperature should be maintained below 40°C with ventilating fan and/or air conditioner(if necessary)and humidity below 90%.

Section of Hoistway

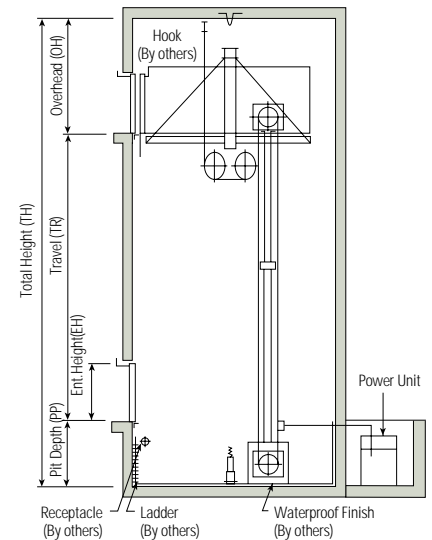
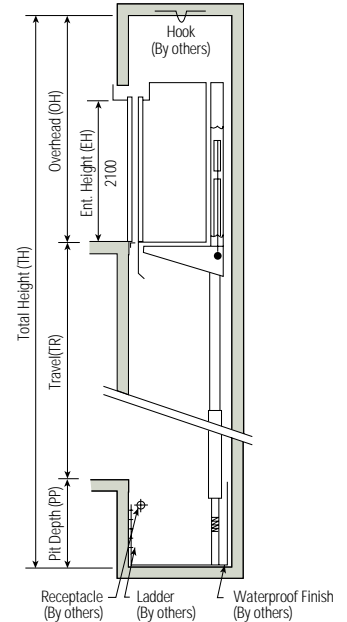

Standard Dimensions

(Unit : mm)

Speed (m/min)	Capacity		Clear Opening	Car		Hoistway	M/C Room	Hitch Beam Reaction (kg)			
	Persons	kg		Internal	External			R1	R2		
			OP	CA × CB	A × B	X × Y	MX × MY				
30	6	450	800	1400 × 850	1460 × 1005	1850 × 1550	2500 × 2500	N/A	N/A		
	8	550	800	1400 × 1030	1460 × 1185	1850 × 1730	2500 × 2500				
	9	600	800	1400 × 1100	1460 × 1255	1850 × 1930	2500 × 2500				
	10	700	800	1400 × 1250	1460 × 1405	1850 × 2080	2500 × 2500				
	11	750	800	1400 × 1350	1460 × 1505	1850 × 2180	2500 × 2500				
45	13	900	900	1600 × 1350	1660 × 1505	2050 × 2180	2800 × 2500	3700	7500		
	15	1000	900	1600 × 1500	1660 × 1655	2050 × 2330	2800 × 2500				
	17	1150	1000	1600 × 1700	1660 × 1870	2550 × 2400	2800 × 2500				
	20	1350	1000	1800 × 1700	1900 × 1870	2750 × 2400	2800 × 2500				
	24	1600	1100	2000 × 1750	2100 × 1920	2950 × 2400	2800 × 2500				
										3950	8000
										4200	8500

Note : The capacity in persons is calculated at 68kg/person. (EN81 75kg/person)

Observation Elevators

Plan of Hoistway & Machine Room

1-Side Observation Type

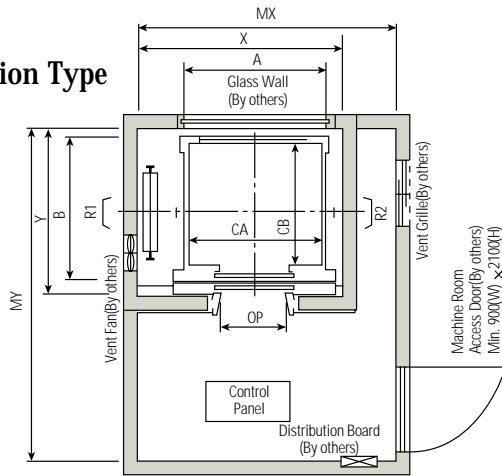

Note : Machine room temperature should be maintained below 40° C with ventilating fan and /or air conditioner(if necessary)and humidity below 90%.

2-Side Observation Type

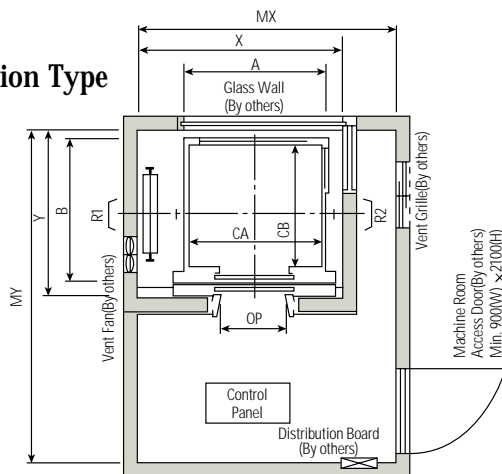

Section of Hoistway

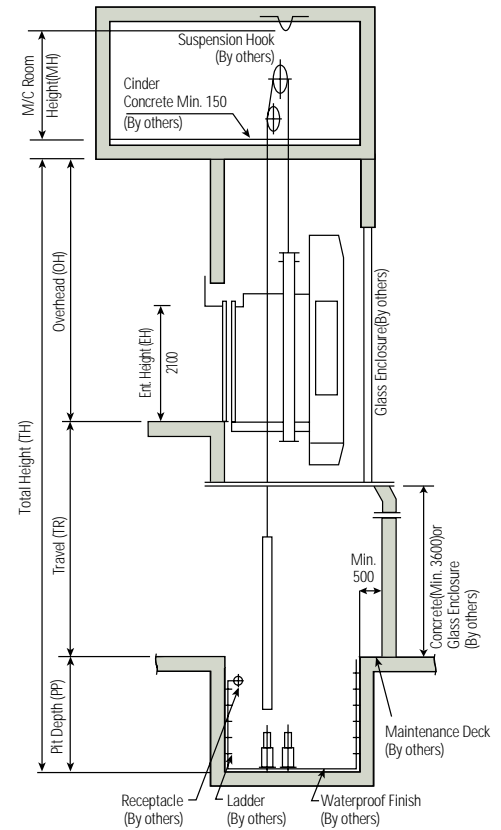

(Unit : mm)

Speed (m/min)	Overhead (OH)	Pit (PP)	M/C Room Height (MH)
45, 60	4800	1800	2200
90	4950	2200	2400
105	5100	2200	2400

Note : Above dimensions are changeable according to the car exterior design.

Standard Dimensions & Reactions

(Unit : mm)

Type	Speed (m/min)	Capacity		Clear Opening OP	Car		Hoistway X × Y	M/C Room MX × MY	M/C Room Reaction(kg)	
		Persons	kg		Internal CA × CB	External A × B			R1	R2
1-Side Observation	45	6	450	800	1400 × 850	1460 × 1060	2200 × 1410	2600 × 2910	3750	2600
		8	550	800	1400 × 1030	1460 × 1240	2200 × 1590	2600 × 3090	4200	2800
		9	600	800	1400 × 1100	1460 × 1310	2200 × 1660	2600 × 3160	4300	2900
		11	750	800	1400 × 1350	1460 × 1560	2200 × 1910	2600 × 3410	4600	3150
	60	13	900	900	1600 × 1350	1660 × 1560	2400 × 1910	3000 × 3410	5200	3950
		15	1000	900	1600 × 1500	1660 × 1710	2400 × 2060	3000 × 3560	5500	4450
		17	1150	1000	1800 × 1500	1900 × 1710	2850 × 2060	3500 × 3560	7550	5500
		20	1350	1000	1800 × 1700	1900 × 1910	2850 × 2260	3500 × 3760	8200	6200
105	24	1600	1100	2000 × 1750	2100 × 1960	3050 × 2310	3700 × 3810	8800	6950	
	2-Side Observation	8	550	800	1400 × 1030	1460 × 1240	2200 × 1590	2600 × 3090	4200	2800
		9	600	800	1400 × 1100	1460 × 1310	2200 × 1660	2600 × 3160	4300	2900
		11	750	800	1400 × 1350	1460 × 1560	2250 × 1910	2700 × 3410	4700	3300
13		900	900	1600 × 1350	1660 × 1560	2450 × 1910	3100 × 3410	5350	4050	
60	15	1000	900	1600 × 1500	1660 × 1710	2450 × 2060	3200 × 3560	5650	4600	
	17	1150	1000	1800 × 1500	1900 × 1710	2900 × 2060	3700 × 3560	7700	5650	
	20	1350	1000	1800 × 1700	1900 × 1910	2900 × 2260	3700 × 3760	8350	6300	
	24	1600	1100	2000 × 1750	2100 × 1960	3100 × 2310	3900 × 3810	9000	7050	

Notes : 1. When non-standard capacities and dimensions are required, consult Hyundai.
 2. The capacity in persons is calculated at 68kg/person. (EN81 75kg/person)
 3. Machine-Room-Less elevators are available, if requested.

Observation Elevators

Plan of Hoistway & Machine Room

Section of Hoistway

3-Side Observation Type

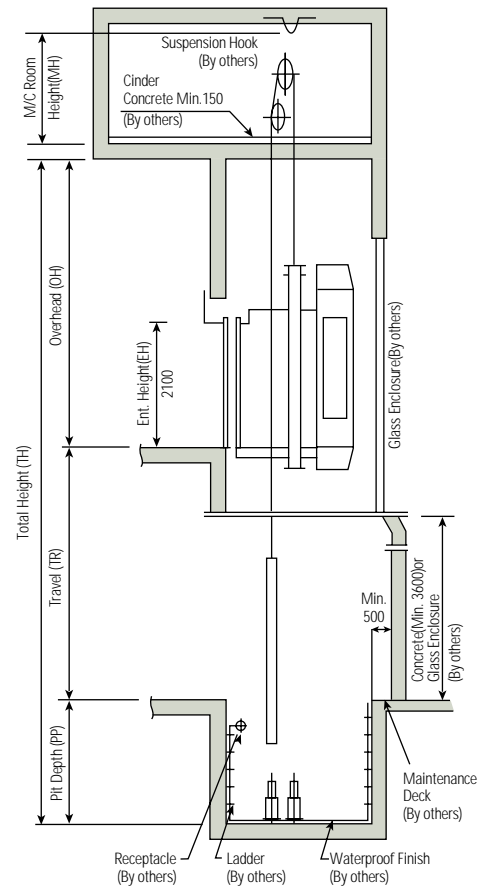
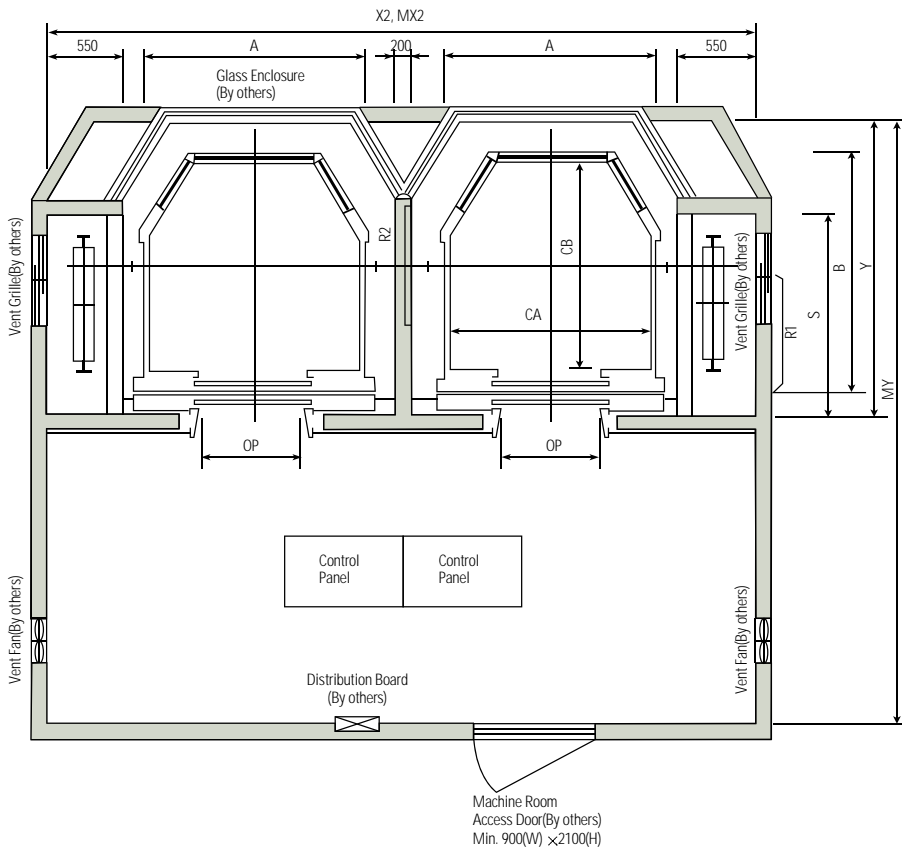

Note: Machine room temperature should be maintained below 40 °C with ventilating fan and/or air conditioner (if necessary) and humidity below 90%.

(Unit : mm)

Speed (m/min)	Overhead (OH)	Pit (PP)	M/C Room Height (MH)
45, 60	4900	2000	2200
90	5050	2200	2400
105	5200	2200	2400

Note: Above dimensions are changeable according to the car exterior design.

Standard Dimensions & Reactions

(Unit : mm)

Speed (m/min)	Capacity		Clear Opening	Car		Hoistway				M/C Room			M/C Room Reaction(kg)	
				Internal	External	1Car	2Cars	Depth	S	1Car	2Cars	Depth	R1	R2
	Persons	kg	OP	CA × CB	A × B	X1	X2	Y	S	MX1	MX2	MY	R1	R2
45	11	750	800	1400 × 1450	1460 × 1660	2450	5100	2010	1200	2900	5100	3510	4900	3500
	13	900	900	1600 × 1450	1660 × 1660	2650	5500	2010	1350	3300	5500	3510	5500	4050
60	15	1000	900	1600 × 1600	1700 × 1810	2650	5500	2160	1350	3300	5500	3710	5750	4700
90	17	1150	900	1500 × 1950	1600 × 2160	2650	5500	2510	1600	3500	5500	4010	8200	6400
105	20	1350	1000	1700 × 1870	1800 × 2080	2850	6100	2430	1600	3500	6100	3930	8500	6600
	24	1600	1000	1800 × 2130	1900 × 2340	3050	6300	2690	1600	3700	6300	4190	9600	7500

Notes: 1. When non-standard capacities and dimensions are required, consult Hyundai.
2. The capacity in persons is calculated at 68kg/person. (EN81 75kg/person)

Plan of Hoistway & Machine Room

Section of Hoistway

Semicircle Observation Type

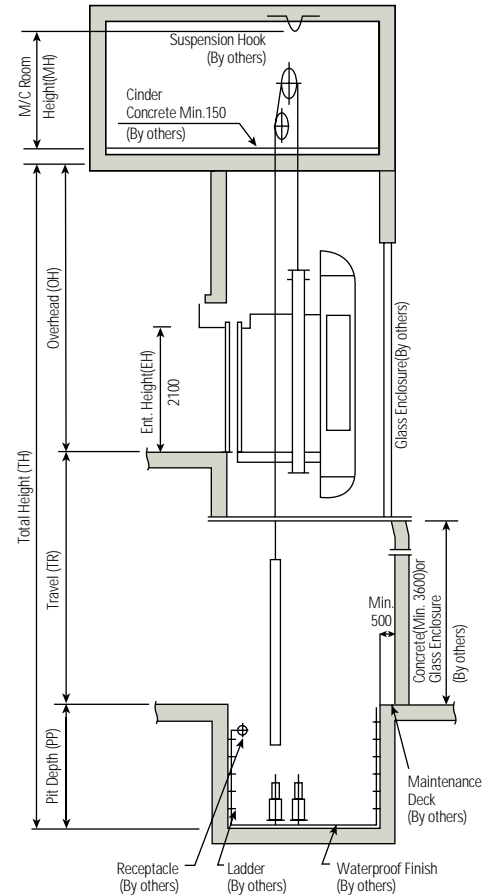
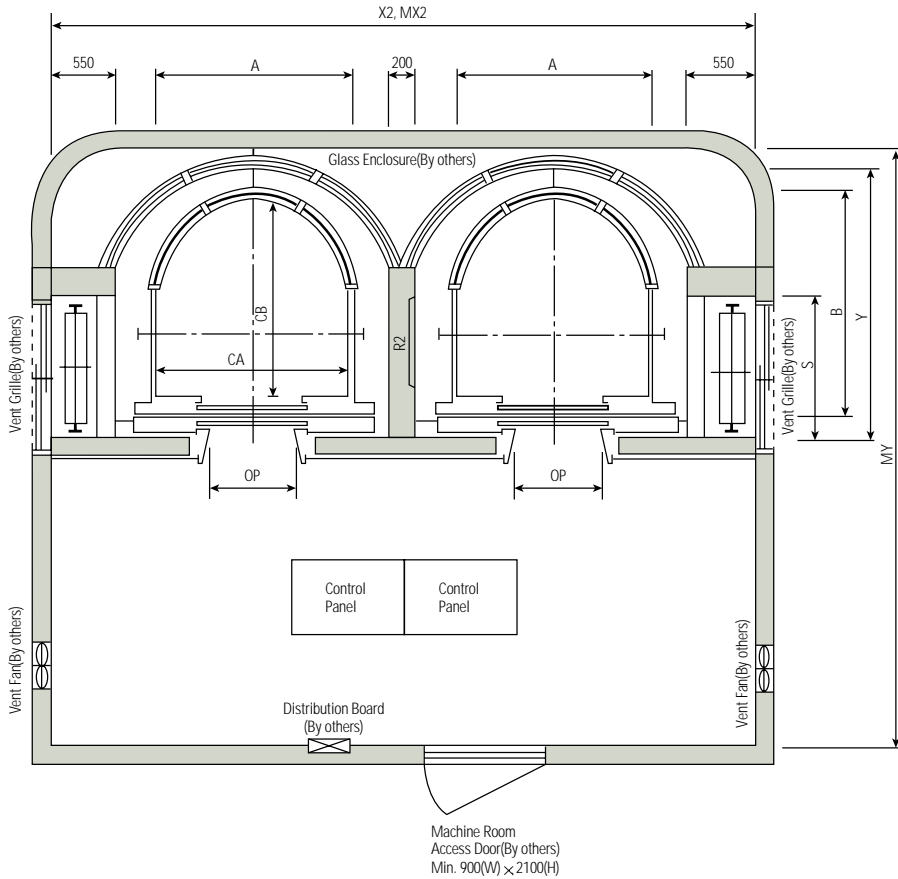

(Unit : mm)

Speed (m/min)	Overhead (OH)	Pit (PP)	M/C Room Height (MH)
45, 60	4900	2000	2200
90	5050	2200	2400
105	5200	2200	2400

Note : Above dimensions are changeable according to the car exterior design.

Note : Machine room temperature should be maintained below 40°C with ventilating fan and/or air conditioner (if necessary) and humidity below 90%.

Standard Dimensions & Reactions

(Unit : mm)

Speed (m/min)	Capacity		Clear Opening	Car		Hoistway				M/C Room			M/C Room Reaction(kg)	
				Internal	External	1Car	2Cars	Depth		1Car	2Cars	Depth	R1	R2
	Persons	kg	OP	CA × CB	A × B	X1	X2	Y	S	MX1	MX2	MY		
45	11	750	800	1400 × 1500	1460 × 1710	2500	5200	2060	1200	3000	5200	3560	5150	3950
	13	900	900	1500 × 1600	1560 × 1810	2600	5400	2160	1350	3300	5400	3660	5700	4500
60	15	1000	900	1500 × 1750	1600 × 1960	2600	5400	2310	1350	3300	5400	3810	5950	4950
90	17	1150	900	1500 × 1950	1600 × 2160	2650	5500	2510	1600	3500	5500	4010	8200	6400
105	20	1350	1000	1700 × 1980	1800 × 2190	2850	5900	2540	1600	3500	5900	4040	8950	6950
	24	1600	1000	1800 × 2130	1900 × 2340	3050	6300	2690	1600	3700	6300	4190	9600	7500

Notes : 1. When non-standard capacities and dimensions are required, consult Hyundai.
2. The capacity in persons is calculated at 68kg/person. (EN81 75kg/person)

Freight Elevators

General Traction Type (2S, 2U, 3U)

Plan of Hoistway & Machine Room

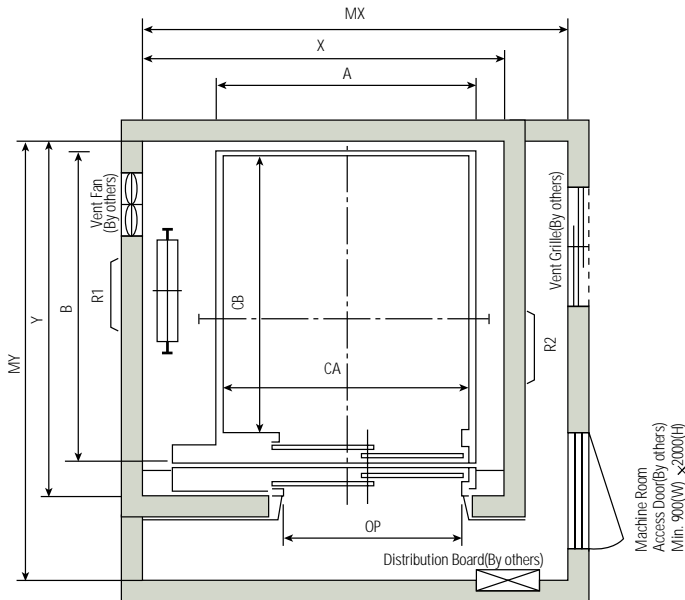

2-PANEL SIDE-OPENING DOORS (2S)

Note : Temperatures should be maintained below 40 °C with ventilating fan and/or air conditioner (if necessary) and humidity below 90%.

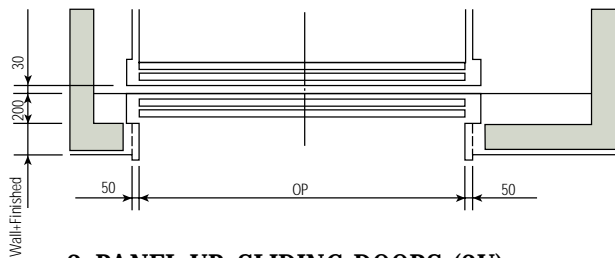

2-PANEL UP-SLIDING DOORS (2U)

- Minimum floor height : $\text{Opening height} \times 3 / 2 + 700\text{mm}$
- Minimum entrance height : 2100mm

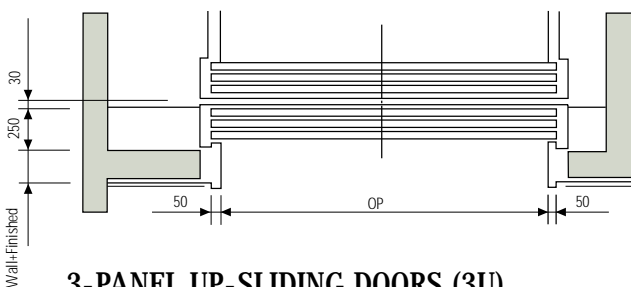

3-PANEL UP-SLIDING DOORS (3U)

- Minimum floor height : $\text{Opening height} \times 4 / 3 + 750\text{mm}$
- Minimum entrance height : 2100mm

Note : Consult Hyundai if the dimensions are less than the minimum.

Section of Hoistway

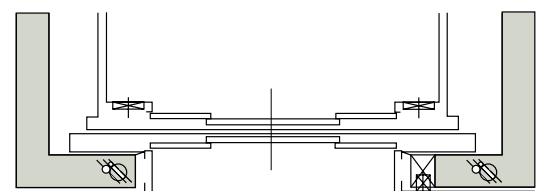
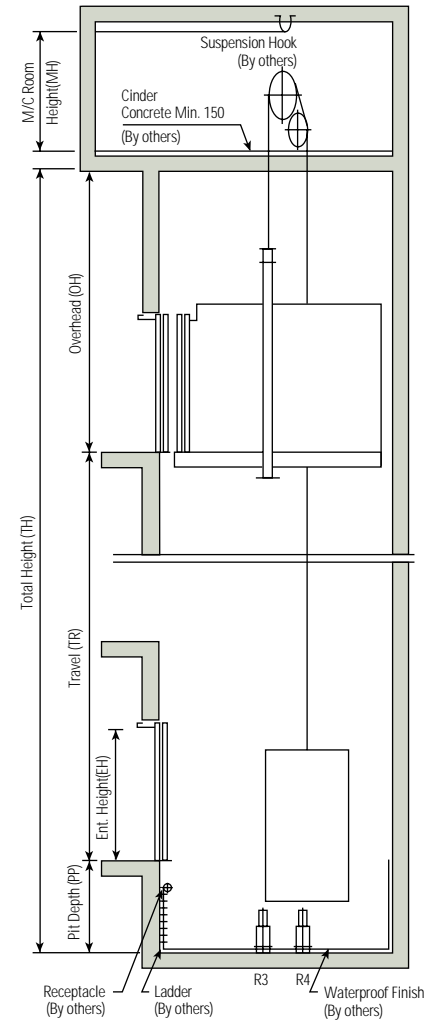

4-PANEL CENTER OPENING DOORS (2CO)

Standard Dimensions & Reactions

(Unit : mm)

Model	Speed (m/min)	Entrance			Car		Hoistway		M/C Room (MX × MY)	M/C Room Reaction (kg)		Buffer Reaction (kg)	
		Door Opening Type	Width × Height (OP × EH)	Entrance Type	Internal	External	X × Y	Overhead (OH)		R1	R2	R3	R4
					CA × CB	A × B							
F0750-2S	30	2S	1100 × 2100	Standard	1700 × 1650	1800 × 1857	2500 × 2150	4800	2800 × 3200	6200	4100	5000	4300
	45			Double Entrance		1800 × 1989	2500 × 2320						
F1000-2S	30	2S	1400 × 2100	Standard	1850 × 1850	1950 × 2078	2750 × 2400	4800	3200 × 3500	8500	5700	7100	6100
	45			Double Entrance		1950 × 2226	2750 × 2600						
F1500-2S	30	2S	1700 × 2100	Standard	2100 × 2500	2200 × 2728	3000 × 3050	4800	3600 × 4000	10800	7100	9000	7500
	45			Double Entrance		2200 × 2876	3000 × 3250						
F2000-2S	30	2S	1700 × 2100	Standard	2300 × 2700	2400 × 2928	3300 × 3250	4800	3800 × 4200	13300	8800	11400	9400
	45			Double Entrance		2400 × 3076	3300 × 3450						
F2000-2U	30	2U	2300 × 2100	Standard	2300 × 2700	2400 × 2898	3300 × 3250	4600	3800 × 4200	13300	8800	11400	9400
	45			Double Entrance		2400 × 3016	3300 × 3490						
F2500-2S	30	2S	1800 × 2100	Standard	2500 × 3000	2600 × 3228	3500 × 3600	4800	4000 × 4400	15100	10000	13200	10700
	45			Double Entrance		2600 × 3376	3500 × 3750						
F2500-2U	30	2U	2500 × 2100	Standard	2500 × 3000	2600 × 3198	3500 × 3600	4600	4000 × 4400	15100	10000	13200	10700
	45			Double Entrance		2600 × 3316	3500 × 3800						
F3000-2U	30	2U	2700 × 2300	Standard	2700 × 3300	2800 × 3498	3700 × 3900	4800	4200 × 4800	15200	10100	13500	10500
	45			Double Entrance		2800 × 3616	3700 × 4100						
F3500-2U	30	2U	2800 × 2500	Standard	2800 × 3800	3020 × 3998	4050 × 4400	5000	4300 × 5200	21700	14500	19000	15500
	45			Double Entrance		3020 × 4116	4050 × 4600						
F4000-3U	25	3U	3000 × 2800	Standard	3000 × 4500	3220 × 4758	4250 × 5250	5300	4500 × 5900	32500	21700	28700	23700
	30			Double Entrance		3220 × 4936	4250 × 5520						
F5000-3U	25	3U	3200 × 3000	Standard	3200 × 5000	3420 × 5258	4450 × 5750	5500	4700 × 6400	36000	23000	31700	26700
	30			Double Entrance		3420 × 5436	4450 × 6020						

- Notes :
1. Please consult Hyundai when the loading capacity is over 5000kg or the car is non-standard size.
 2. The loading capacity should be over 250kg/m² minimally.
 3. The actual reaction may slightly differ from above dimensions in line with machine beam position.

(Unit : mm)

Speed (m/min)	Pit (PP)	M/C Room Height (MH)
30, 45	1250	2400
60	1500	2600

- Notes :
1. Above is minimum size.
 2. Refer to standard dimensions & reactions for overhead height.

Automobile Elevators

General Traction Type (2U, 3U)

Plan of Hoistway & Machine Room

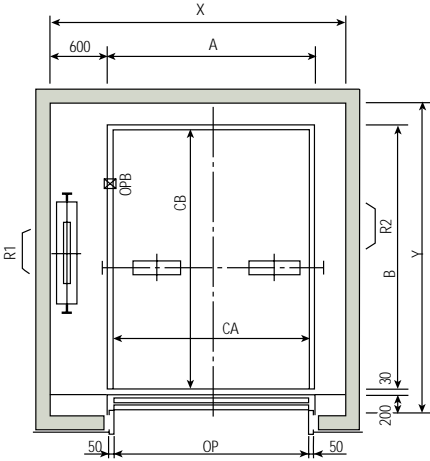

2-PANEL UP-SLIDING DOORS (2U)

- Minimum floor height : Opening height $\times 3 / 2 + 700\text{mm}$
- Minimum entrance height : 1800mm

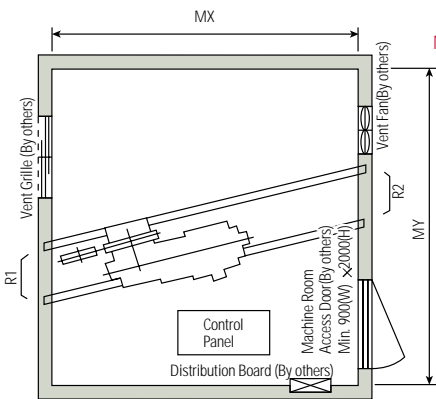

- Notes : 1. Temperatures should be maintained below 40 °C with ventilating fan and/or air conditioner (if necessary) and humidity below 90%.
2. The specification of car doors is optional.

(Unit : mm)

Speed (m/min)	Overhead (OH)	Pit (PP)	M/C Room Height (MH)
30, 45	4400	1200	2400

Note : Above is minimum size.

Section of Hoistway

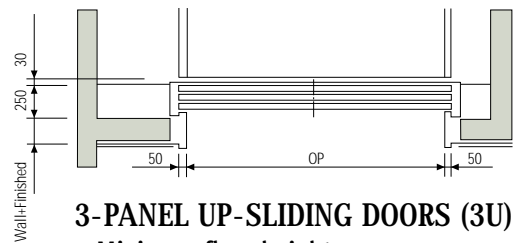
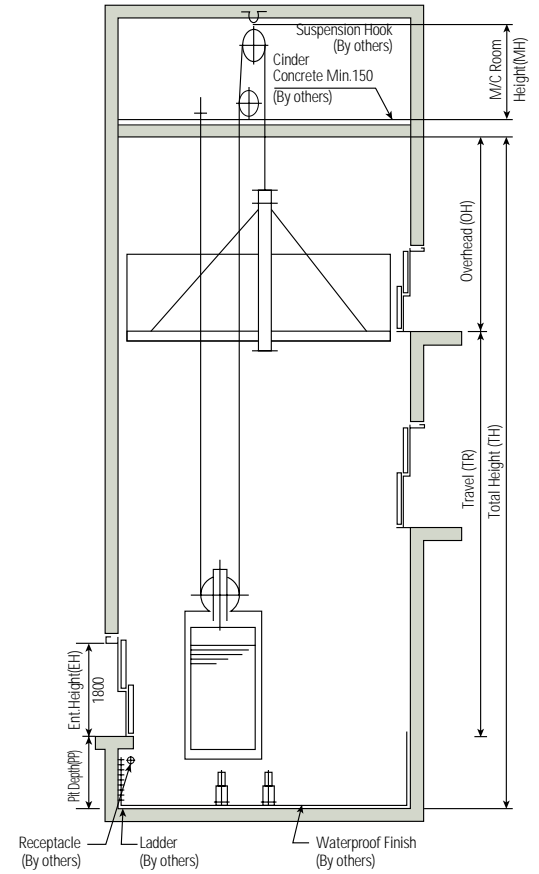

3-PANEL UP-SLIDING DOORS (3U)

- Minimum floor height : Opening height $\times 4 / 3 + 750\text{mm}$
- Minimum entrance height : 1800mm

Note : Consult Hyundai if the dimensions are less than the minimum.

Standard Dimensions & Reactions

(Unit : mm)

Type	Model	Speed (m/min)	Clear Opening	Car		Hoistway	M/C Room	M/C Room Reaction(kg)		
				OP	Internal			External	R1	R2
					CA \times CB			A \times B		
Standard Type	A2000-2U	30, 45	2350	2350 \times 5300	2450 \times 5350	3300 \times 5800	3300 \times 5800	17500	12000	
	A2500-2U	30, 45	2750	2750 \times 6300	2850 \times 6350	3700 \times 6800	3850 \times 6800	22500	12500	
	A2000-3U	30, 45	2350	2350 \times 5300	2450 \times 5350	3300 \times 5800	3300 \times 5800	17500	12000	
	A2500-3U	30, 45	2750	2750 \times 6300	2850 \times 6350	3700 \times 6800	3850 \times 6800	22500	12500	
Double Entrance Type	A2000-2UD	30, 45	2350	2350 \times 5300	2450 \times 5300	3300 \times 5800	3300 \times 5800	17500	12000	
	A2500-2UD	30, 45	2750	2750 \times 6300	2850 \times 6300	3700 \times 6800	3850 \times 6800	22500	12500	
	A2000-3UD	30, 45	2350	2350 \times 5300	2450 \times 5300	3300 \times 5800	3300 \times 5800	17500	12000	
	A2500-3UD	30, 45	2750	2750 \times 6300	2850 \times 6300	3700 \times 6800	3850 \times 6800	22500	12500	

- Notes : 1. The car external size can be varied in line with entrance type.
2. When non-standard capacities and dimensions are required, consult Hyundai.

Automobile Elevators

Hydraulic Indirect Type (2U, 3U)

Plan of Hoistway & Machine Room

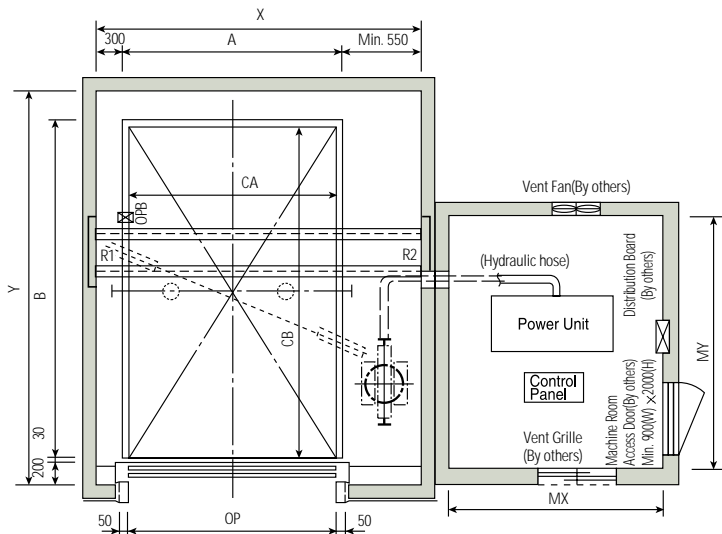

2-PANEL UP-SLIDING DOORS (2U)

- Minimum floor height : $\text{Opening height} \times 3 / 2 + 700\text{mm}$
- Minimum entrance height : 1800mm

- Notes :
1. The specification of car doors is optional.
 2. Machine room temperature should be maintained below 40°C with ventilating fan and/or air conditioner (if necessary) and humidity below 90%.

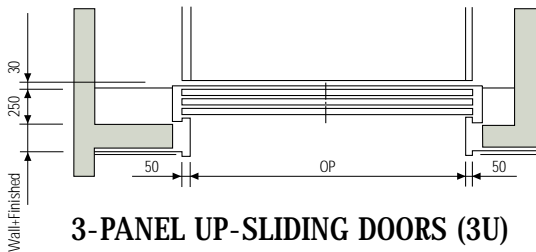

3-PANEL UP-SLIDING DOORS (3U)

- Minimum floor height : $\text{Opening height} \times 4 / 3 + 750\text{mm}$
- Minimum entrance height : 1800mm

Section of Hoistway

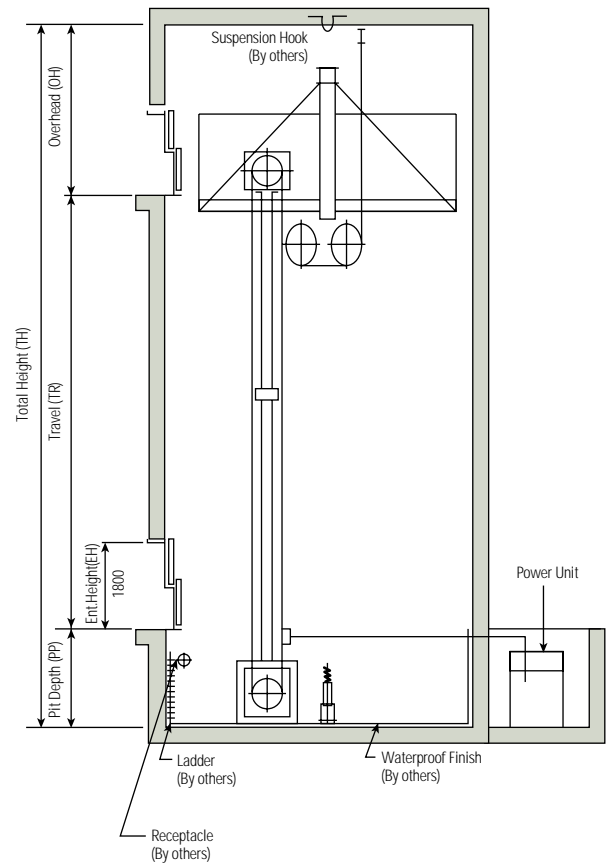

(Unit : mm)

Speed (m/min)	Overhead (OH)	Pit (PP)	M/C Room Height (MH)	Travel (TR)
20, 30, 45	3600	1200	2000	20m

- Notes :
1. Above is minimum size.
 2. Consult Hyundai if the travel height is 20m and over.
 3. Consult Hyundai if the dimensions are less than the minimum.

Standard Dimensions & Reactions

(Unit : mm)

Type	Model	Speed (m/min)	Clear Opening OP	Car		Hoistway X × Y	M/C Room MX × MY	M/C Room Reaction(kg)	
				Internal CA × CB	External A × B			R1	R2
Standard Type	HA2000-2U	20,30,45	2350	2350 × 5300	2450 × 5350	3300 × 5800	2500 × 2800	5500	250
	HA2500-2U	20,30,45	2750	2750 × 6300	2850 × 6350	3700 × 6800	2500 × 2800	6400	300
	HA2000-3U	20,30,45	2350	2350 × 5300	2450 × 5350	3300 × 5800	2500 × 2800	5500	250
	HA2500-3U	20,30,45	2750	2750 × 6300	2850 × 6350	3700 × 6800	2500 × 2800	6400	300
Double Entrance Type	HA2000-2UD	20,30,45	2350	2350 × 5300	2450 × 5300	3300 × 5800	2500 × 2800	5500	250
	HA2500-2UD	20,30,45	2750	2750 × 6300	2850 × 6300	3700 × 6800	2500 × 2800	6400	300
	HA2000-3UD	20,30,45	2350	2350 × 5300	2450 × 5300	3300 × 5900	2500 × 2800	5500	250
	HA2500-3UD	20,30,45	2750	2750 × 6300	2850 × 6300	3700 × 6900	2500 × 2800	6400	300

- Notes :
1. The car external size can be varied in line with entrance type.
 2. When non-standard capacities and dimensions are required, consult Hyundai.

Hospital Bed Elevators

General Traction Type (2S, 2SD)

Plan of Hoistway & Machine Room

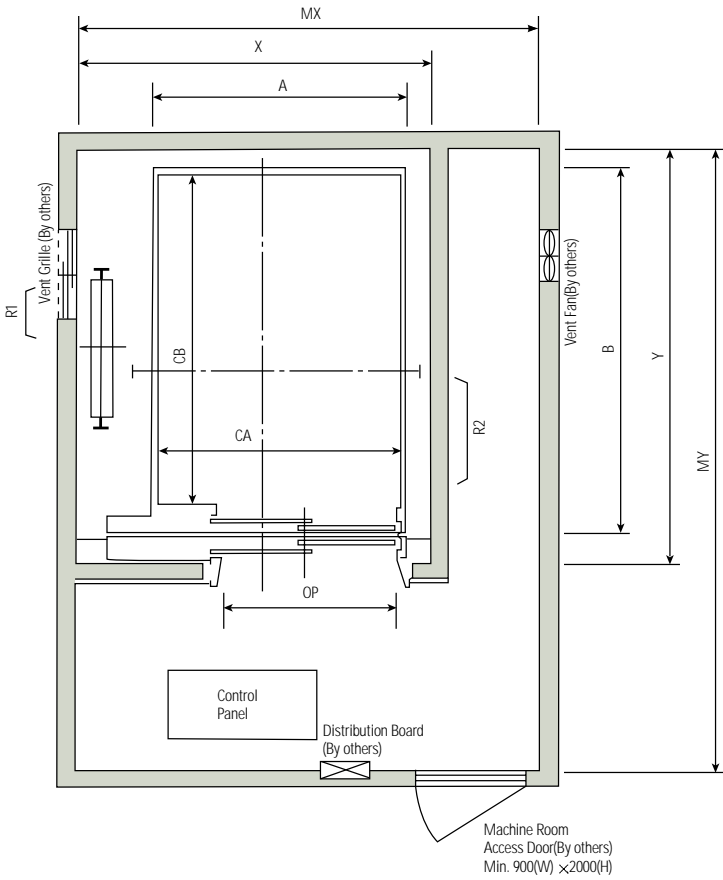

(Unit : mm)

Speed (m/min)	Overhead (OH)	Pit (PP)	M/C Room Height (MH)
30, 45	4400	1200	2200
60	4600	1500	
90	4800	1800	2400
105	5000	2100	

Section of Hoistway

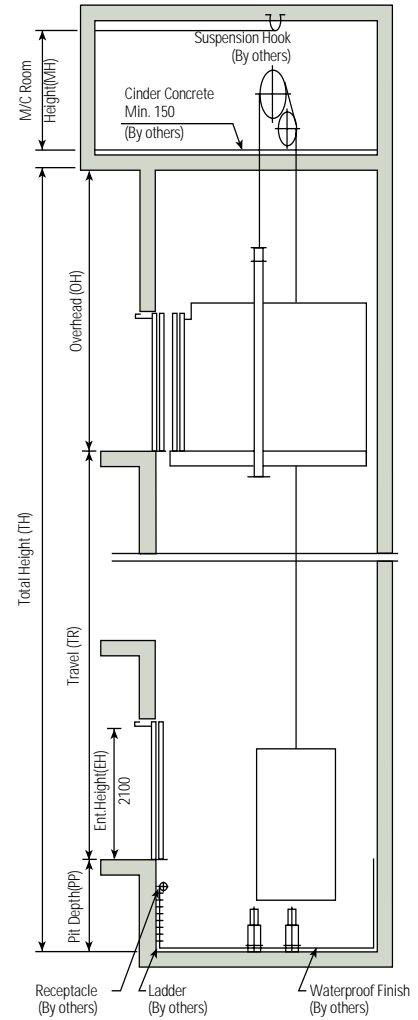

- Notes :**
1. Machine room temperature should be maintained below 40°C with ventilating fan and/or air conditioner, if necessary, and humidity below 90%.
 2. In case of special hoistway, machine room height may be higher than above size.
 3. Above is minimum size.

Standard Dimensions & Reactions

(Unit : mm)

Type	Model	Speed (m/min)	Clear Opening OP	Car		Hoistway X × Y	M/C Room MX × MY	M/C Room Reaction(kg)	
				Internal CA × CB	External A × B			R1	R2
Standard Type	B750-2S	30, 45	1100	1300 × 2300	1360 × 2492	2050 × 2850	2300 × 3500	5790	3450
		60						5900	3750
	B1000-2S	30, 45	1200	1500 × 2500	1560 × 2692	2300 × 3050	2750 × 4000	6500	3700
		60						6800	4100
Double Entrance Type	B750-2SD	30, 45	1100	1300 × 2300	1360 × 2634	2050 × 3000	2300 × 3500	5790	3450
		60						5900	3700
	B1000-2SD	30, 45	1200	1500 × 2500	1560 × 2834	2450 × 3200	2750 × 4000	9300	3700
		60						9500	4100

- Notes :**
1. When non-standard capacities and dimensions are required, consult Hyundai.
 2. Above dimensions are applied to standard door only. In case fire protection door is applied, hoistway size for 1 car should be applied above X dimension plus 100 mm.

Typical Entrance Layouts

Entrance

Structural Opening of Entrance

In case of Boxless Type Buttons and Fire man's Switch

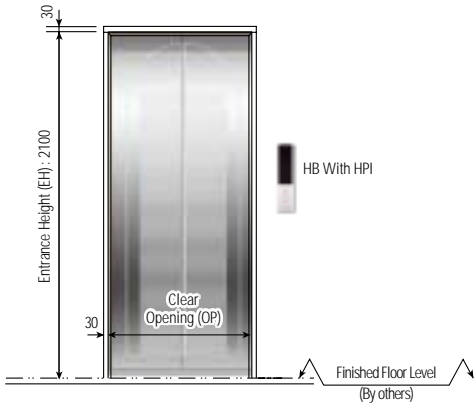

JP050 Type(Basic)

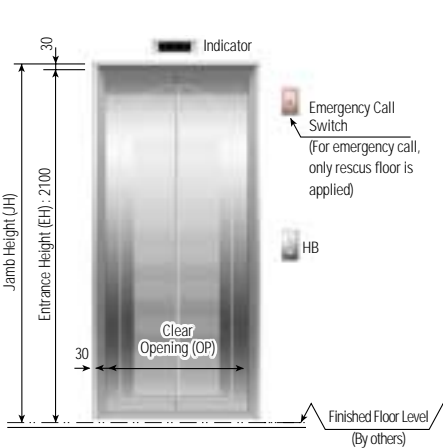
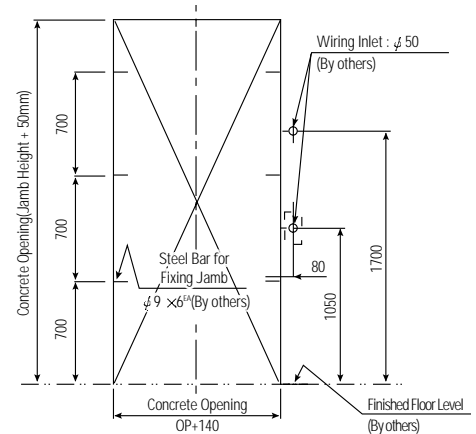
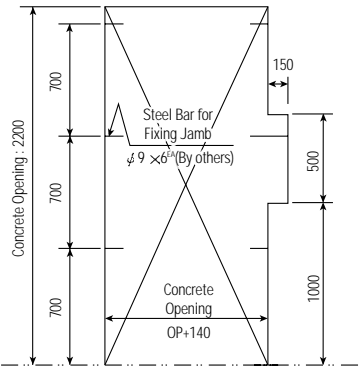

JP100 Type(Optional)

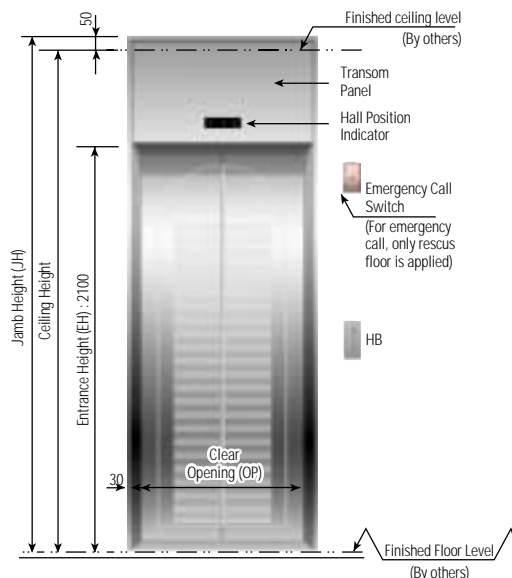
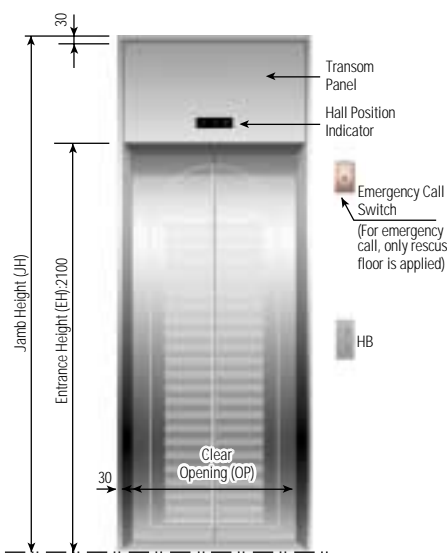
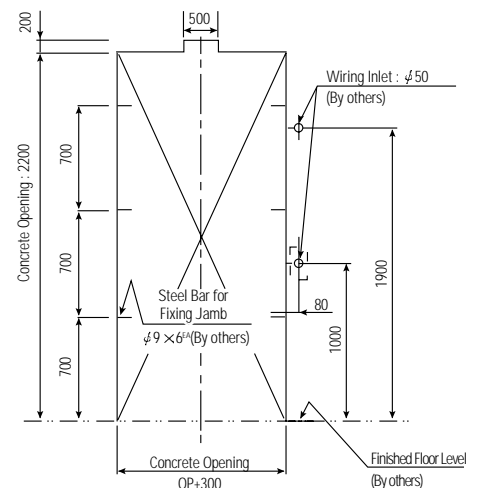
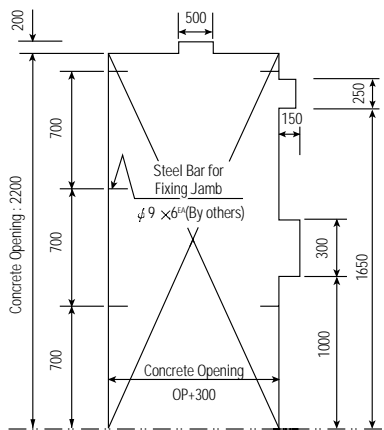

JP200 Type(Optional)

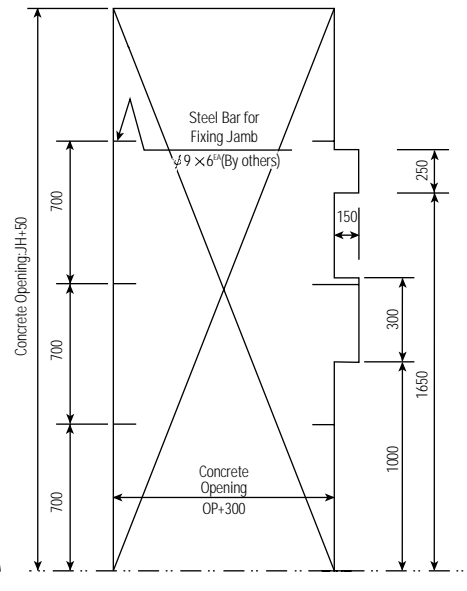

Typical Entrance Layouts

Only for Floor with Control Panel of the Machine-Room-Less Elevators

Entrance Design

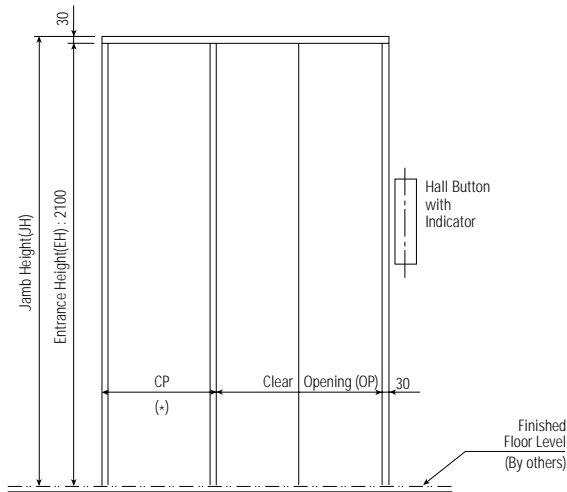

CP110 Type (Standard)

Structural Opening of Entrance

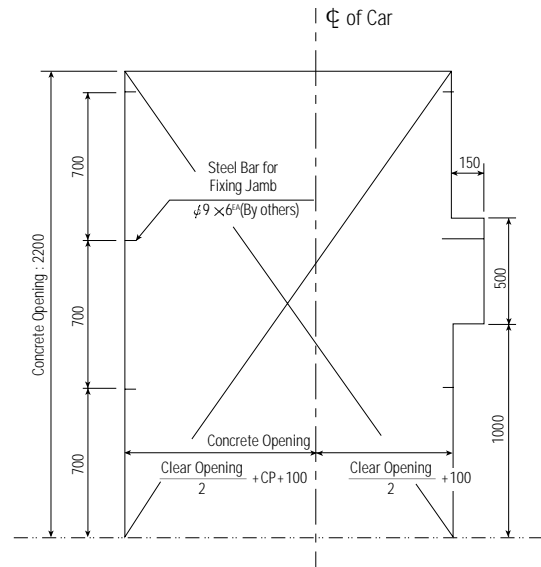

CP110 Type (Standard)

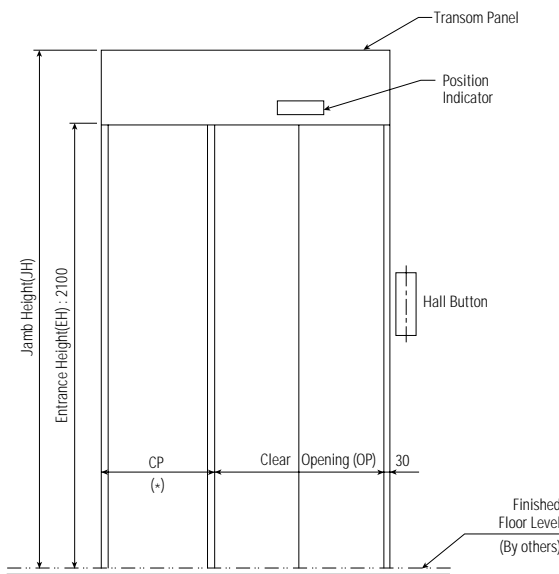

CP210 Type (Optional)

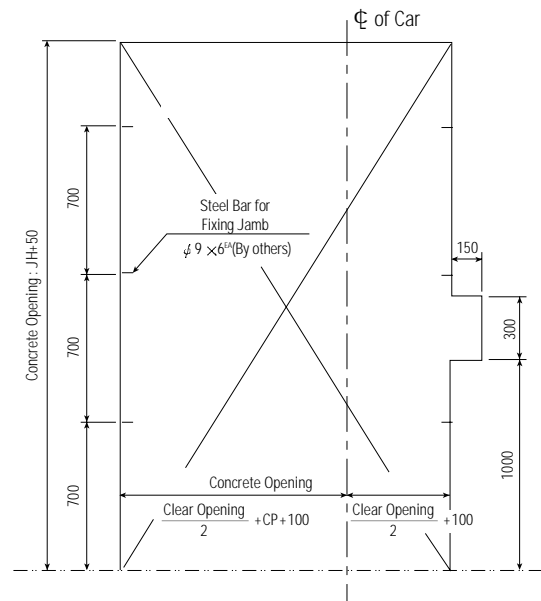

CP210 Type (Optional)

(Unit : mm)

Persons	Speed(m/min)	Width of Control Panel(CP)(-)
8-17	Under 105	530
20, 24	60	530
	90	630
	105	630

2-PANEL CENTER-OPENING DOORS (CO) LAYOUT

Plan of Entrance

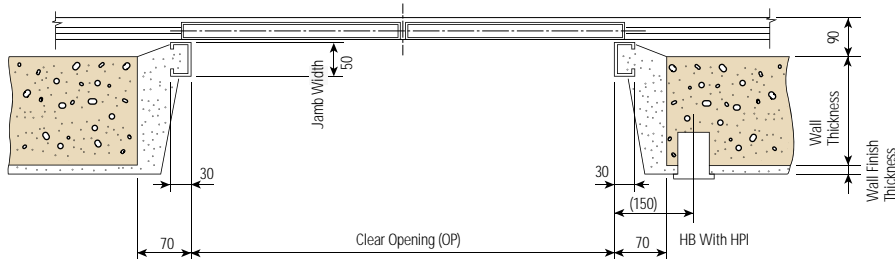

JP050 Type

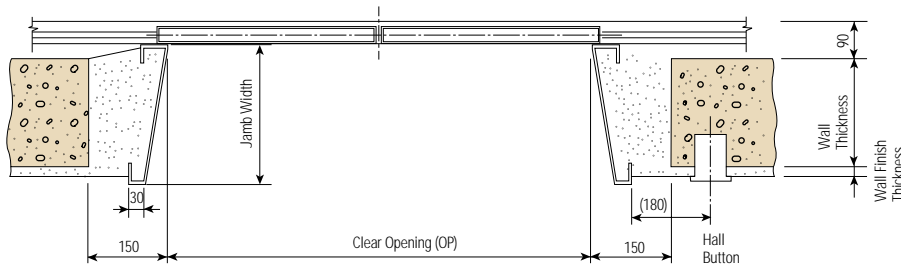

JP100, JP200 Type

Section Entrance

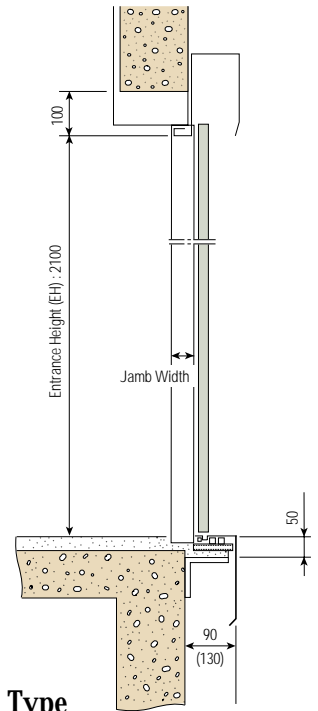

JP050 Type

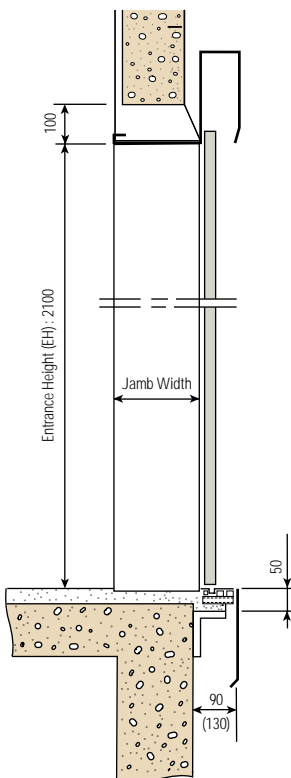

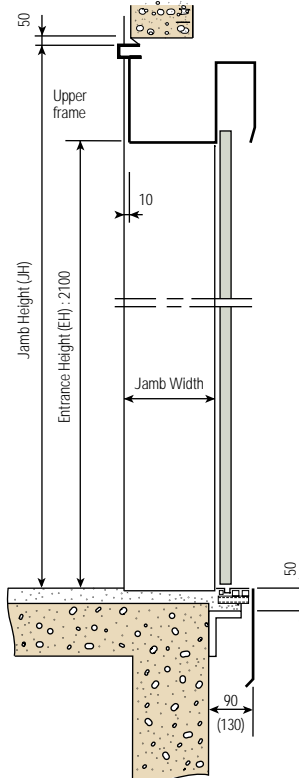

JP100 Type

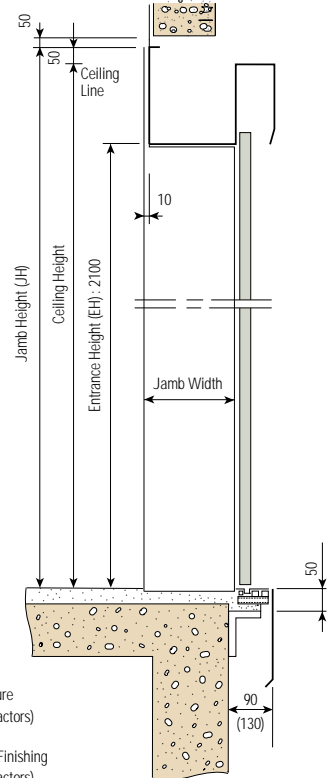

JP200 Type
(with upper frame)



JP200 Type
(without upper frame)

-  Building Structure
(By other Contractors)
-  Wall and Floor Finishing
(By other Contractors)

Note : Sizes shown in () are applied to 120m/min-600m/min.

Typical Entrance Layouts

2-PANEL SIDE-OPENING DOORS (2S) LAYOUT

Plan of Entrance

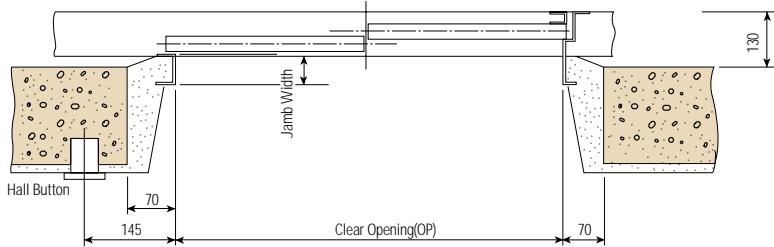

JP050 Type

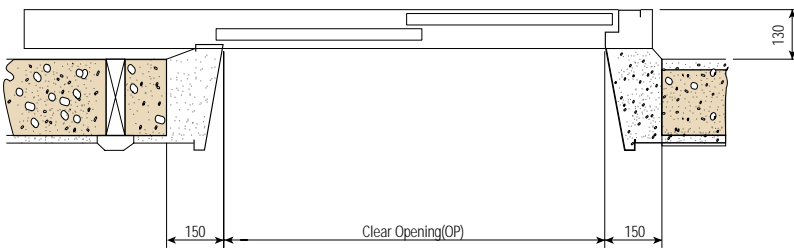

JP100, JP200 Type

※ The above layout is for left side opening. Right side opening doors are available, if requested.

Section Entrance

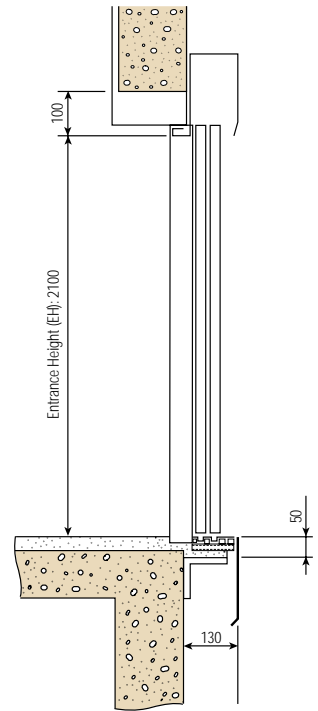

2-PANEL UP-SLIDING DOORS (2U) LAYOUT

Entrance Design

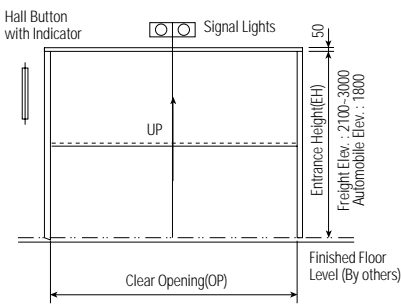

Structural Opening of Entrance

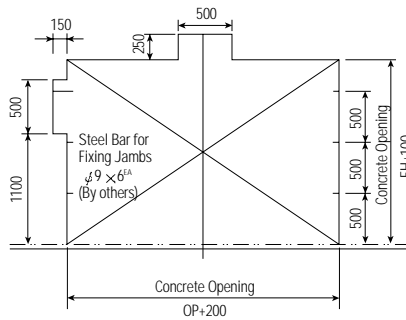

Section of Entrance

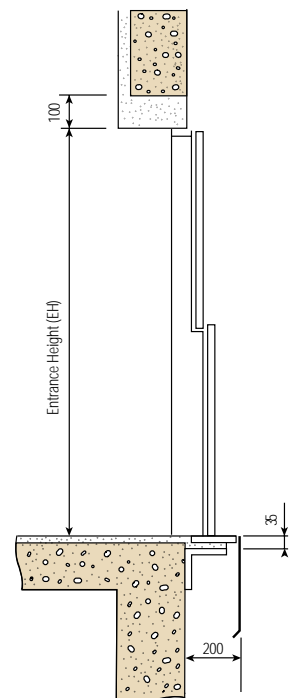

Plan of Entrance

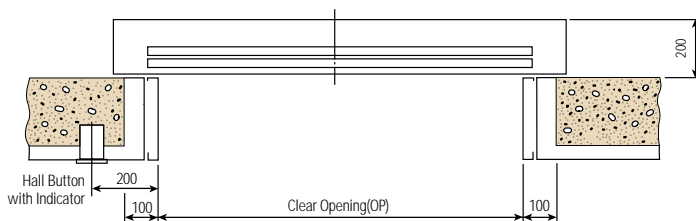

- Notes : 1. The standard location of Hall Button with Indicator for automobile elevators is on left wall but it is on the right wall for freight elevators.
 (· Minimum floor height : Opening Height \times 3/2 + 700mm
 · Minimum entrance height : 1800mm)
 2. Consult Hyundai if the dimensions are less than the minimum.

Works To Be Done By Other Contractors

The following works are not included in the elevator contract, and shall be done by other contractors in accordance with the Hyundai Elevator's drawings and the applicable codes and regulations.

The reference rules shown are from ANSI A17.1 Code.

I Building Work

Hoistway

1. Clear, plumb hoistway with fire resistant hatch walls as required by the governing code. (Rule 100.1a)
2. 75° bevel guards on all projections, recesses or setbacks over 50mm except on side used for loading or unloading. (Rule 100.6)
3. Venting of the hoistway as required by the governing code or authority. (Rule 100.4)
4. Supports for rail brackets at each floor, roof, and machine room. (Rule 200.9)
Maximum allowable vertical spacing of rail supports, without backing. (Rule 200.4 and 301.1)
Divider beams 100mm between hoistway at each floor and roof, for guide rail bracket supports. (Rule 200.4, 200.9 and 301.1)
5. Recesses, supports and patching as required to accommodate hall button boxes, signal fixtures, etc.
6. All barricades either outside elevator hoistways or between elevators inside hoistways as required.
7. Dry pit reinforced to sustain normal vertical forces from rails and buffers. (Rule 106.1b and 109)
Consult Hyundai Elevator Company for rail forces and buffer impacts.
Where there is space below the pit floor which can be occupied, consult Hyundai Elevator Company for special requirements. (Rule 300.4)
Cylinder hole, casings under the pit as required and backfilling around the cylinder casings when direct plunger type is to be installed.
8. Where access to the pit is by means of the lowest hoistway entrance, vertical iron ladder extending 1060mm minimum above sill of access door. (Rule 106.1d)
9. Entrance walls and finished floor are not to be constructed until after door frames and sills are in place.
Door frames are to be anchored to walls and properly grouted in place to maintain legal fire rating.
10. Sill supports 64mm minimum floor recesses full hoistway width for entrance sills, with grouting after sills are set in place.
11. For application as indoor observation elevator, a minimum 3.6m high glass enclosure above bottom landing is recommended for safety.
For application as outdoor observation elevator, full height glass enclosure is required.

Machine Room

12. Enclosed and protected machine room. (Rule 101.1)
13. Access to the machine room and machinery space as required by the governing code or authority. (Rule 101.3)
14. Reinforced concrete machine room floor slab or grating, as specified, which must not be placed over the hoistway until elevator machinery is set in position. (Rule 100.3 for Traction Elevator)
Clear access above ceiling or trench in floor, for oil line and wiring duct from machine room, if machine room is remote from elevator hoistway. (For Hydraulic Elevator)
Cutout through machine room wall, for oil line and wiring duct as required by the Hyundai Elevator's shop drawings. (For Hydraulic Elevator)
15. Hoisting beams, trap doors and other means of access to machine room for maintenance and equipment removal purposes. (Rule 101.3d)
16. Cable guards in the machine room or secondary level. (Rule 104.1)
17. Supports for machine and sheave beams and reactions including wall pockets and patching after beams are set in place. (Rule 105.1 to 105.5)

II Electrical Work

Hoistway

1. Light outlet for each elevator, in center of hoistway (or in machine room) as indicated by Hyundai Elevator Company.
2. Convenience outlet and light fixture in pit with switch located adjacent to the access door. (Rule 106.1e)
3. Wiring and piping work of emergency bell, interphone, etc.
Outside the hoistway and the machine room.

Machine Room

4. Lighting, convenience outlets, ventilation, heating of machine room, and machinery space. (Rule 101.5)
5. Temperature should be maintained below 40°C with ventilating fan and/or air conditioner, if necessary, and humidity below 90%.
6. A fused disconnect switch or circuit breaker for each elevator and light switch located per the governing code and where practicable located adjacent to the door of the machine room. (Rule 210.5 and 306.7)
7. Feeder and branch wiring to the controller, including main-line switch and convenience outlets.
8. Suitable power feeder and branch wiring circuits as required for elevators with power operated doors, including disconnect switch or circuit breaker.

Emergency Provisions

9. Elevator fireman's and other emergency services wiring and interconnections to automatic sprinkler systems or heat and smoke sensing devices furnished by others and installed to terminal points on the elevator controllers.
10. When emergency power operation of elevators is required, the electrical contractor should coordinate with Hyundai Elevator Company or local distributor for operation requirements.
11. Elevator fireman's and other emergency service requirements may differ from each country.
Consult Hyundai Elevator Company or local distributor for other local requirements.
12. When provisions for earthquake protection are required, consult Hyundai Elevator Company for special requirements.

Heat Emission of Machine Room

$$Q(\text{kcal/H}) = W \times V \times F \times N$$

W: Capacity (kg)

N: Number of cars

V: Speed (m/min)

F: Factor (1/40: VWF)

Electric Power Requirements (by Others)

VVVF

(50/60Hz, 380v)

Persons (kg)	Speed (m/min)	Motor (kW)	C.B. Rated Current (A)		Transformer Capacity (KVA)		Power Feeder (mm ²)		Earth Wire (mm ²)	
			1Car	2Cars	1Car	2Cars	1Car	2Cars	1Car	2Cars
6 (450)	60	5.5 (2.8)	20 (10)	30 (20)	4 (3)	7 (5)	4 (4)	6 (4)	4 (4)	4 (4)
	90	7.5 (4.1)	20 (20)	30 (40)	6 (4)	10 (8)	4 (4)	6 (10)	4 (4)	6 (6)
	105	7.5 (4.8)	20 (20)	40 (40)	7 (5)	12 (9)	4 (4)	10 (10)	4 (4)	6 (6)
	120	11	30	50	8	14	6	16	4	6
8 (550)	60	5.5 (3.4)	20 (10)	30 (20)	5 (4)	9 (6)	4 (4)	6 (4)	4 (4)	4 (4)
	90	7.5 (5.1)	20 (20)	30 (40)	7 (5)	13 (10)	4 (4)	6 (10)	4 (4)	4 (6)
	105	11 (5.9)	30 (20)	50 (40)	8 (6)	15 (11)	6 (4)	16 (10)	4 (4)	6 (6)
	120	11	30	50	9	17	6	16	4	6
9 (600)	60	5.5 (3.7)	20 (20)	30 (30)	5 (4)	9(7)	4 (4)	6 (6)	4 (4)	4 (4)
	90	11 (5.6)	30 (20)	50 (40)	8 (6)	14 (10)	6 (4)	16 (10)	4 (4)	6 (6)
	105	11 (6.5)	30 (20)	50 (40)	9 (7)	16 (12)	6 (4)	16 (10)	4 (4)	6 (6)
	120	11	30	60	10	19	6	16	4	10
10 (700)	60	7.5 (4.2)	20 (20)	40 (30)	6 (5)	11 (8)	4 (4)	10 (6)	4 (4)	6 (4)
	90	11 (6.3)	30 (20)	50 (40)	9 (7)	16 (12)	6 (4)	16 (10)	4 (4)	6 (6)
	105	11 (7.3)	30 (20)	60 (40)	11 (8)	19 (14)	6 (4)	16 (10)	4 (4)	10 (6)
	120	15	40	75	12	22	10	25	6	10
11 (750)	60	7.5 (4.6)	20 (20)	40 (30)	6 (5)	12 (9)	4 (4)	10 (6)	4 (4)	6 (4)
	90	11 (6.9)	30 (20)	50 (40)	10 (7)	17 (13)	6 (4)	16 (10)	4 (4)	6 (6)
	105	11 (8.1)	30 (30)	60 (50)	11 (8)	20 (15)	10 (6)	16 (16)	4 (4)	10 (6)
	120	15 (9.2)	40 (30)	75 (50)	13 (10)	23 (17)	10 (6)	25 (16)	6 (4)	10 (6)
13 (900)	60	11 (5.6)	30 (20)	50 (30)	8 (6)	14 (10)	6 (4)	10 (6)	4 (4)	6 (4)
	90	15 (8.3)	40 (30)	60 (50)	12 (9)	21 (16)	10 (6)	16 (16)	6 (4)	10 (6)
	105	15 (9.7)	40 (30)	75 (50)	14 (10)	24 (18)	10 (6)	25 (16)	6 (4)	10 (6)
	120	18.5 (11.1)	50 (30)	100 (60)	15 (12)	28 (21)	16 (6)	35 (16)	6 (4)	10 (10)
15 (1000)	60	11 (6.2)	30 (20)	50 (40)	9 (6)	15 (12)	6 (4)	16 (10)	4 (4)	6 (6)
	90	15 (9.2)	40 (30)	75 (50)	13 (10)	23 (17)	10 (6)	25 (16)	6 (4)	10 (6)
	105	15 (10.8)	40 (30)	75 (60)	15 (11)	27 (20)	10 (6)	25 (16)	6 (4)	10 (10)
	120	18.5 (12.3)	50 (40)	100 (75)	17 (13)	31 (23)	16 (10)	35 (25)	6 (6)	10 (10)
17 (1150)	60	11 (7.1)	30 (20)	50 (40)	10 (7)	18 (13)	6 (4)	16 (10)	4 (4)	6 (6)
	90	15 (10.6)	40 (30)	75 (60)	15 (11)	27 (20)	10 (6)	25 (16)	6 (4)	10 (10)
	105	18.5 (12.4)	50 (30)	100 (60)	17 (13)	31 (23)	16 (6)	35 (16)	6 (4)	10 (10)
	120	22 (14.1)	60 (40)	100 (75)	20 (15)	36 (27)	16 (10)	35 (25)	6 (6)	10 (10)
20 (1350)	60	15 (8.3)	30 (20)	60 (40)	12 (9)	21 (16)	10 (6)	16 (10)	6 (4)	6 (6)
	90	18.5 (12.5)	50 (40)	100 (75)	17 (13)	31 (24)	16 (10)	25 (16)	6 (6)	10 (10)
	105	22 (14.5)	50 (40)	100 (75)	20 (15)	37 (28)	16 (10)	35 (25)	6 (6)	10 (10)
	120	30 (16.6)	75 (40)	125 (100)	23 (17)	42 (31)	16 (10)	35 (25)	10 (6)	16 (10)
24 (1600)	60	15 (9.9)	40 (30)	75 (50)	14 (10)	25 (19)	10 (6)	25 (16)	6 (6)	10 (6)
	90	22 (14.8)	50 (50)	100 (75)	21 (16)	37 (28)	16 (10)	35 (25)	6 (6)	10 (10)
	105	22 (17.2)	60 (50)	125 (100)	24 (18)	43 (33)	16 (16)	35 (25)	10 (6)	16 (10)
	120	30 (19.7)	75 (50)	125 (100)	28 (21)	50 (37)	25 (16)	35 (25)	10 (6)	16 (10)

Notes : 1. Above power feeder sizes are for the length of electric wire up to 50m from elevator machine room to transformer.

For the length being 50m or more, the following formular should be applied:

$$2. \text{ Above power feeder sizes are for copper wires inside electrometallic tubings. Power feeder sizes(mm}^2\text{) = } \frac{\text{Power feeder length(m)}}{50} \times \text{Size in the above(mm}^2\text{)}$$

3. For power requirement of 3 cars or more, consult Hyundai.

4. Machine room temperature should be maintained below 40 °C with ventilating fan and air conditioner, and humidity below 90%.

5. Data shown in () is applied to the Machine-Room-Less elevators. (Gearless type)

AC-Gearless

(50/60Hz, 380V)

Persons (kg)	Speed (m/min)	Motor (kW)	C.B. Rated Current(A)		Transformer Capacity (kVA)		Power Feeder (mm ²)		Earth Wire (mm ²)		Persons (kg)	Speed (m/min)	Motor (kW)	C.B. Rated Current(A)		Transformer Capacity (kVA)		Power Feeder (mm ²)		Earth Wire (mm ²)	
			1Car	2Cars	1Car	2Cars	1Car	2Cars	1Car	2Cars				1Car	2Cars	1Car	2Cars	1Car	2Cars		
13 (900)	150	13.8	50	100	15	28	10	25	6	16	20 (1350)	210	30	100	175	33	60	25	50	16	35
	180	16.6	50	100	18	33	10	25	6	16		240	35	125	200	39	70	35	70	25	50
15 (1000)	150	15.4	50	100	17	31	10	25	6	16		300	42	125	225	47	84	35	70	25	50
	180	18.4	60	100	20	37	10	25	6	16		360	50	150	300	56	100	50	120	35	95
	210	23	75	125	26	46	16	35	10	25		420	58	150	300	64	116	50	120	35	95
	240	26	100	150	29	52	25	50	16	35		480	67	175	300	74	134	50	120	35	95
17 (1150)	150	17.7	60	100	20	35	10	25	6	16		540	75	200	350	83	150	70	150	50	120
	180	21.2	75	125	24	42	16	35	10	25		600	83	225	400	92	166	70	185	70	150
	210	25	75	150	28	50	16	50	10	35		150	24.5	75	150	27	49	16	50	10	35
	240	30	100	175	33	60	25	50	16	35		180	30	100	175	33	60	25	50	16	35
	300	36	125	200	40	72	35	70	25	50	210	35	125	200	39	70	35	70	25	50	
	360	43	125	200	48	86	35	70	25	50	240	40	125	225	44	80	35	70	25	50	
	420	50	125	225	56	100	35	70	25	50	300	50	150	300	56	100	50	120	35	95	
	480	57	150	300	63	114	50	120	35	95	360	60	175	350	67	120	50	150	35	120	
20 (1350)	150	20.7	75	125	23	41	16	35	10	25	420	69	175	350	77	138	50	150	35	120	
	180	25	75	150	28	50	16	50	10	35	480	79	200	350	88	158	70	150	50	120	
											540	89	225	400	99	178	70	185	70	150	
											600	98	250	500	109	196	95	240	95	185	

Notes : 1. The above power sizes are for lengths of electric wire up to 50 meters from the elevator machine room to the transformer.

For lengths of 50 meters or more, the following formula should be applied :

$$\text{Power feeder size (mm}^2\text{)} = \frac{\text{Power feeder length (m)}}{50} \times \text{size in the above (mm}^2\text{)}$$

Number of elevator(N)	1	2	3	4	5
Diversity factor	1.00	0.91	0.85	0.80	0.76

2. Above power feeder sizes are for copper wires inside electro-metallic tubing.

3. It is recommended a larger diameter earth wire be used.

4. For installing several elevators, apply the following formula.

$$\text{Transformer Capacity (kVA)} = \text{Number of elevator} \times \text{Diversity factor}$$

5. Consult Hyundai if you need electric power requirements for 220V.

6. For AC-Geared elevators, consult Hyundai.

Hydraulic

(50/60Hz, 380V)

Persons (kg)	Speed (m/min)	Motor (kW)	C.B. Rated Current (A)		Transformer Capacity (kVA)		Power Feeder (mm ²)		Earth Wire (mm ²)		Heat Emission of Machine Room (kcal/h)		Ventilation of Machine Room (#/h)	
			1Car	2Cars	1Car	2Cars	1Car	2Cars	1Car	2Cars	1Car	2Cars	1Car	2Cars
6 (450)	30	15	50	100	25	45	10	25	6	6	3000	6000	1000	2000
	45	22	75	150	38	70	16	50	6	10	3900	7800	1300	2600
8 (550)	30	18.5	75	125	30	56	16	35	6	6	3500	7000	1100	2200
	45	30	100	175	49	90	25	70	6	10	5500	11000	1900	3800
9 (600)	30	18.5	75	125	30	56	16	35	6	6	3500	7000	1100	2200
	45	30	100	175	49	90	25	70	6	10	5500	11000	1900	3800
10 (680)	30	18.5	75	125	30	56	16	35	6	6	3500	7000	1100	2200
	45	30	100	175	49	90	25	70	6	10	5500	11000	1900	3800
11 (750)	30	18.5	75	125	30	56	16	35	6	6	3500	7000	1100	2200
	45	30	100	175	49	90	25	70	6	10	5500	11000	1900	3800
13 (900)	30	30	100	175	49	90	25	70	6	10	5500	11000	1900	3800
	45	37	125	225	62	113	35	120	6	10	6900	13800	2300	4600
15 (1000)	30	30	100	175	49	90	25	70	6	10	5500	11000	1900	3800
	45	37	125	225	62	113	35	120	6	16	6900	13800	2300	4600
17 (1150)	30	37	125	225	62	113	35	120	6	16	6900	13800	2300	4600
	45	52	175	300	81	148	50	150	10	25	9700	19400	3500	7000
20 (1350)	30	37	125	225	62	113	35	120	6	16	6900	13800	2300	4600
	45	52	175	300	81	148	50	150	10	25	9700	19400	3500	7000
24 (1600)	30	37	125	225	62	113	35	120	6	16	6900	13800	2300	4600
	45	52	175	300	81	148	50	150	10	25	9700	19400	3500	7000

Notes : 1. Above power feeder sizes are for the length of electric wire up to 50m from elevator machine room to transformer.

For the length being 50m or more, the following formula should be applied:

$$\text{Power feeder size (mm}^2\text{)} = \frac{\text{Power feeder length (m)}}{50} \times \text{Size in the above (mm}^2\text{)}$$

3. For power requirement of 3 cars or more, consult Hyundai.

4. Machine room temperature should be maintained below 40 °C with ventilating fan and air conditioner, and humidity below 90%.

5. The heat emission and ventilation of machine room on above dimensions may vary slightly with the machine room size and peripheral environment.

6. Consult Hyundai if you need electric power requirements for 220V.

Worldclass Escalators 30°

W-BT, W-BTL, W-BB

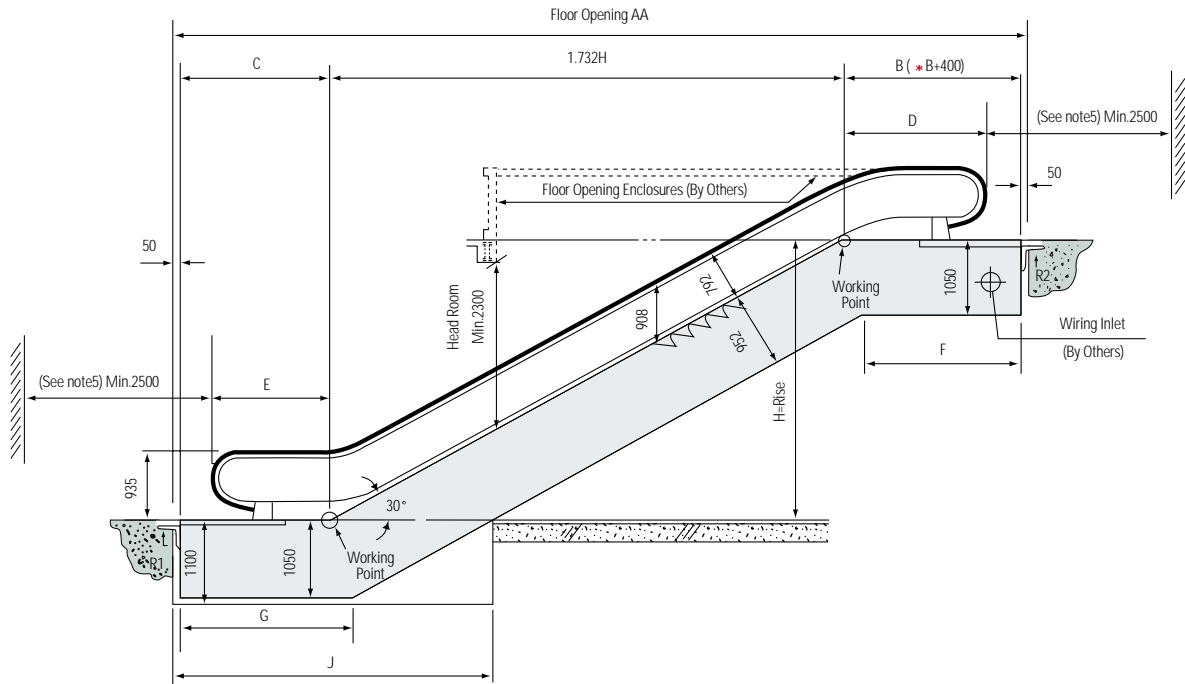

- Notes :**
1. $AA=1.732H+B+C+100$
 2. In case inverter system is applied, consult Hyundai.
 3. Escalator for subway or semi-outdoor escalator :
(*)Dimension
 4. When vertical rise is over 6000mm, 3-flat step is applied.
 5. Dimension between the end of handrail to the wall ; Min.2500mm

Model (Inclination)	Q'ty of Flat Step	B	C	D	E	F	G	J
W-BT	2	2273	2070	1693	1490	2224	2118	4300
W-BTL	3	2680	2477	2100	1897	2631	2525	4740
W-BB	2	2400	2070	1820	1490	2351	2118	4300
	3	2807	2477	2227	1897	2758	2525	4740

Section Dimensions (Unit : mm)

Type	W800	W1000	W1200
W1	594	813	1014
W2	839	1057	1257
W3	1132	1350	1550
W4	1082	1300	1500
W5	1232	1450	1650

Typical Concrete Support

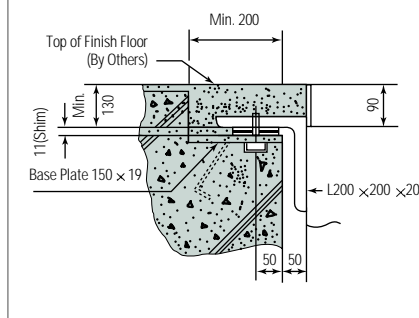

Typical Steel Support

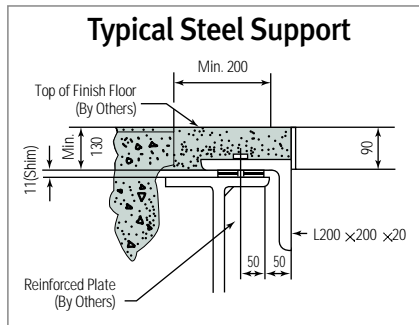

- Notes :**
1. When maximum floor opening exceeds $AA=14835\text{mm}$, intermediate support(s) are required. Consult Hyundai for the intermediate support data.
 2. Consult Hyundai if the isolation pad is applied.

Reactions (Unit : kg)

Vertical Rise (mm)	W800		W1000		W1200	
	R1	R2	R1	R2	R1	R2
3000	3600	4200	4100	4700	4500	5150
3200	3725	4335	4200	4850	4660	5315
3400	3850	4470	4300	5000	4820	5480
3600	3975	4605	4450	5150	4980	5645
3800	4100	4740	4600	5300	5140	5810
4000	4225	4875	4750	5450	5300	5975
4200	4350	5010	4900	5600	5460	6140
4400	4475	5145	5050	5750	5620	6305
4600	4600	5280	5200	5900	5780	6470
4800	4725	5415	5350	6050	5940	6635
5000	4850	5550	5500	6200	6100	6800
5200	4975	5685	5650	6350	6260	6965
5400	5100	5820	5800	6500	6420	7130
5600	5225	5955	5900	6650	6580	7295
5800	5300	6090	6050	6800	6740	7460
6000	5475	6225	6200	6950	6900	7625

Note : When vertical rise is over 6000mm, consult Hyundai for reactions data.

Motor Application (Speed: 30m/min)

Type	Vertical Rise H(mm)			
W800	$H \leq 7600$	$H \leq 9000$	$H \leq 10500$	-
W1000	$H \leq 5000$	$H \leq 7600$	$H \leq 9000$	$H \leq 10500$
W1200	$H \leq 4200$	$H \leq 6000$	$H \leq 7600$	$H \leq 10500$
Motor(kW)	5.5	7.5	11	15

Note : When speed is over 40m/min, consult Hyundai.

Worldclass Escalators 35°

W-BT, W-BTL

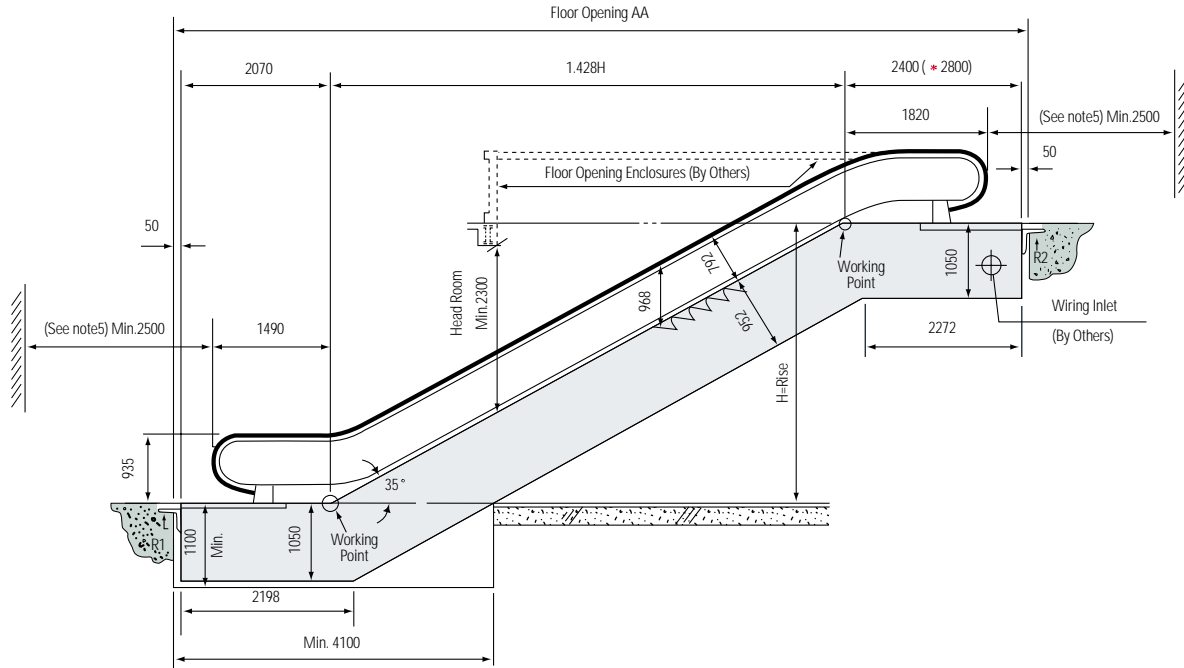

- Notes:**
1. $AA = 1.428 \times H + 2400 (*2800) + 2070 + 100$
 2. Q'ty of flat step : 2
 3. In case inverter system is applied, consult Hyundai.
 4. Escalator for subway or semi-outdoor escalator : (*)Dimension
 5. Dimension between the end of handrail to the wall; Min.2500mm
 6. Maximum rise : 6000mm is available.

Section Dimensions (Unit : mm)

Type	W800	W1000	W1200
W ₁	612	813	1014
W ₂	855	1057	1257
W ₃	1147	1350	1550
W ₄	1097	1300	1500
W ₅	1248	1450	1650

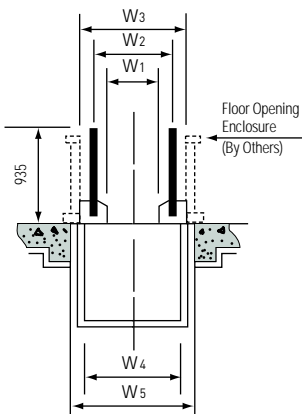

Typical Concrete Support

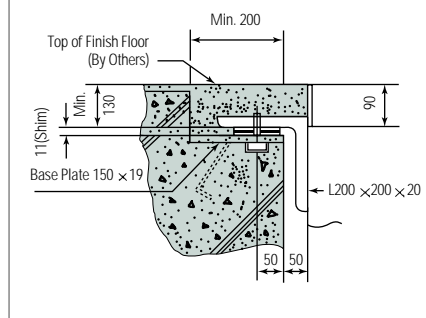

Typical Steel Support

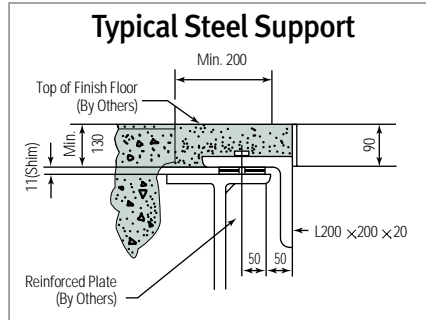

- Notes:**
1. When maximum floor opening exceeds $AA=14835\text{mm}$, intermediate support(s) are required. Consult Hyundai for the intermediate support data.
 2. Consult Hyundai if the isolation pad is applied.

Reactions (Unit : kg)

Vertical Rise H(mm)	W800		W1000		W1200	
	R1	R2	R1	R2	R1	R2
3000	3520	4120	3950	4605	4400	5050
3200	3645	4255	4100	4750	4560	5215
3400	3770	4390	4200	5000	4720	5380
3600	3895	4525	4350	5145	4880	5545
3800	4020	4660	4500	5295	5040	5710
4000	4145	4795	4650	5445	5200	5875
4200	4270	4930	4800	5595	5360	6040
4400	4395	5065	4950	5745	5520	6205
4600	4520	5200	5100	5895	5680	6370
4800	4645	5335	5250	6045	5840	6535
5000	4770	5470	5400	6195	6000	6700
5200	4895	5605	5550	6345	6160	6865
5400	5020	5740	5700	6495	6320	7030
5600	5145	5875	5850	6645	6480	7195
5800	5270	6010	6000	6795	6640	7360
6000	5395	6145	6150	6945	6800	7525

Motor Application (Speed:30m/min)

Type	Vertical Rise H(mm)	
W800	$H \leq 5800$	$H \leq 6000$
W1000	$H \leq 5000$	$H \leq 6000$
W1200	$H \leq 4200$	$H \leq 6000$
Motor(kW)	5.5	7.5

Modular Escalators

M-BTL

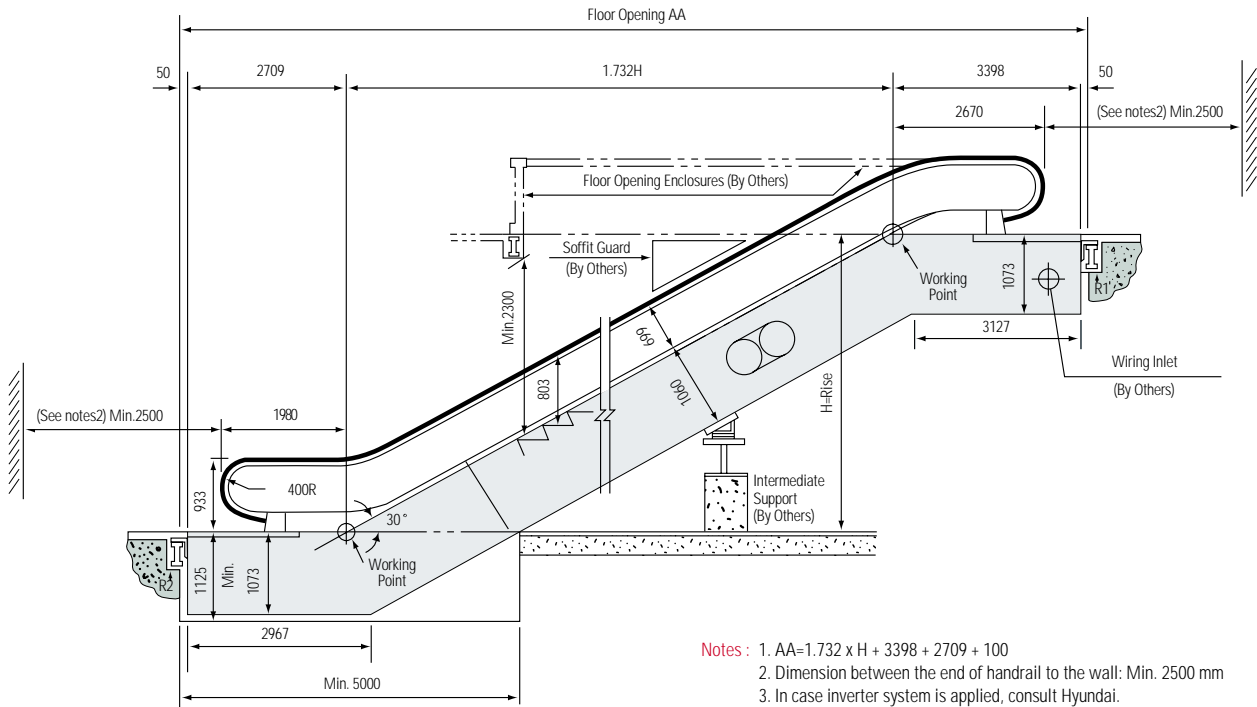

- Notes:**
1. $AA = 1.732 \times H + 3398 + 2709 + 100$
 2. Dimension between the end of handrail to the wall: Min. 2500 mm
 3. In case inverter system is applied, consult Hyundai.

Section Dimensions (Unit : mm)

Type	M800	M1200
W1	594	1014
W2	895	1342
W3	1275	1695
W4	1244	1664
W5	1375	1795

Typical Concrete Support

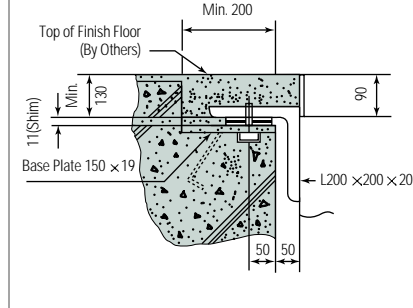

Reactions

AA Unit : m

	M800	M1200
R1	$R1 = 485(AA + 0.1) - \frac{3800}{AA + 0.1} + 1500$	$R1 = 635(AA + 0.1) - \frac{3800}{AA + 0.1} + 1800$
R2	$R2 = 485(AA + 0.1) + \frac{3800}{AA + 0.1} + 600$	$R2 = 635(AA + 0.1) + \frac{3800}{AA + 0.1} + 800$

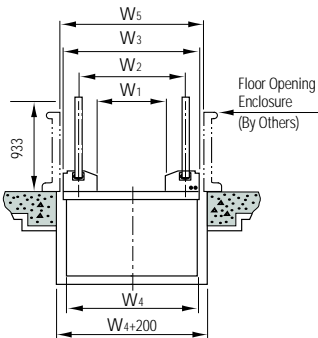

Typical Steel Support

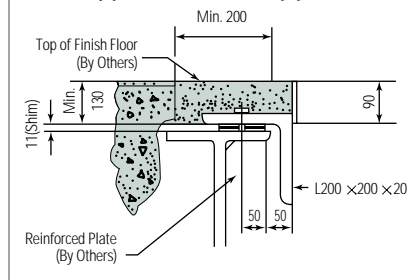

- Notes:**
1. When maximum floor opening exceeds $AA = 10000\text{mm}$, intermediate support(s) are required. Consult Hyundai for the intermediate support data.
 2. Consult Hyundai if the isolation pad is applied.

Motor Application

Speed: 30m/min

Type	M800	M1200	MOTOR (kw)
Vertical Rise : H(mm)	$2440 \leq H \leq 3660$	$2440 \leq H \leq 3660$	5.5 × 1
	$H \leq 9140$	$H \leq 6100$	7.5 × 1
	$H \leq 10970$	$H \leq 7320$	5.5 × 2
	$H \leq 14980$	$H \leq 11000$	7.5 × 2
	$H \leq 27430$	$H \leq 18290$	7.5 × 3
	$H \leq 36580$	$H \leq 24380$	7.5 × 4
	—	$H \leq 30480$	7.5 × 5
—	$H \leq 36580$	7.5 × 6	

H-Series Escalators

HA-BTL

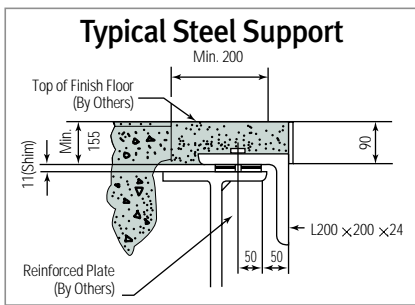
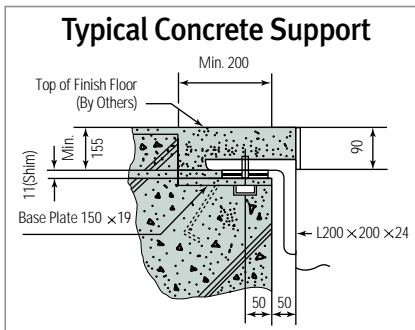
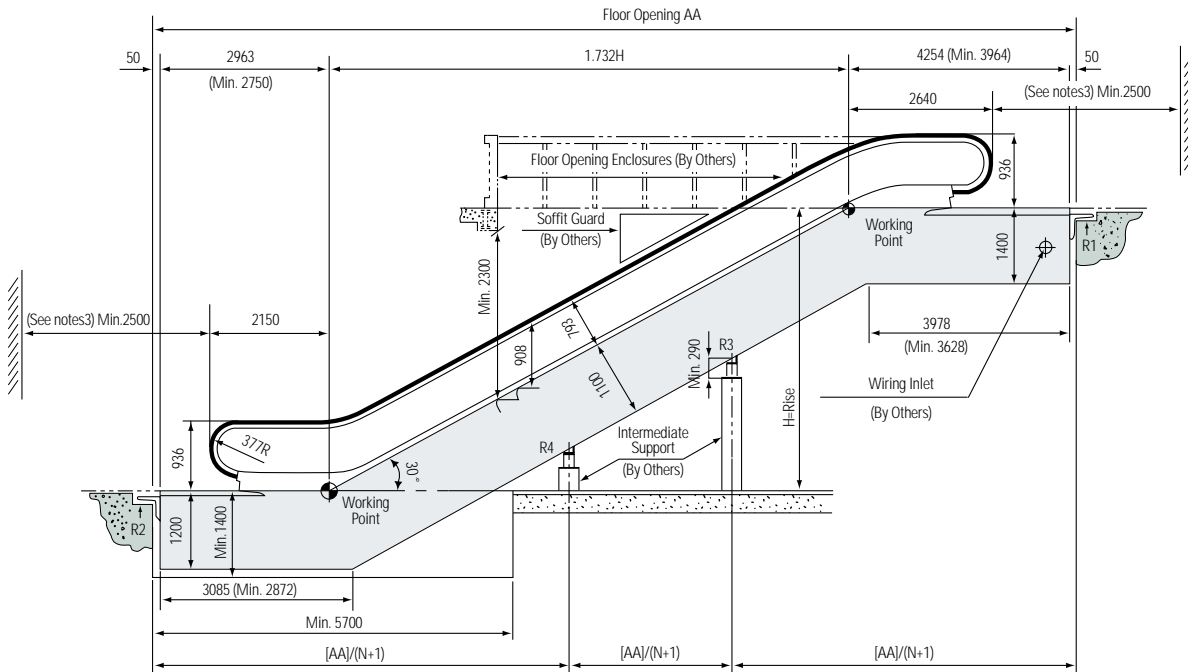

- Notes:**
- When maximum floor opening exceeds AA=10000mm, intermediate support(s) are required. Consult Hyundai for the intermediate support data.
 - Consult Hyundai if the isolation pad is applied.

Section Dimensions (Unit : mm)

Type	HA800	HA1000	HA1200
W ₁	594	813	1014
W ₂	986	1205	1406
W ₃	1330	1549	1750
W ₄	1280	1499	1700
W ₅	1430	1650	1850

- Notes:**
- N : Number of intermediate support
Max. distance between intermediate support 10000 mm
AA=1.732 x H + 4100 (3750) + 2963 (2750) + 100
 - Dimension between the end of handrail to the wall: Min. 2500 mm
 - In case inverter system is applied, consult Hyundai.
 - Above dimensions are applied to standard vertical motor only.

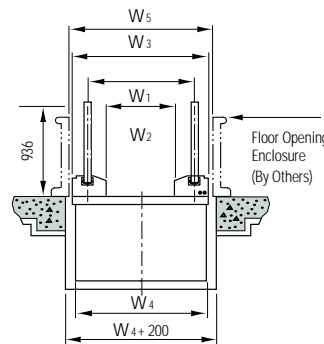

Motor Application Speed : 30m/min

Type	Vertical Rise : H(mm)			
	H ≤ 13000	17800	13600	15000
HA800	17800	13600	-	-
HA1000	-	13400	13600	-
HA1200	-	H ≤ 11000	H ≤ 12800	H ≤ 15000
Motor (kW)	11	16	18.5	22

Note: Above dimensions are applied in case the 3 flat step is standard.

Reactions (Unit : kg)

Vertical Rise H (mm)	7600	8000	8400	8800	9200	9600	10000	10400	10800	11200	11600	12000	12400	12800	13200	13600	
Floor Opening AA(mm)	20326	21019	21711	22404	23097	23790	24483	25175	25868	26561	27254	27847	28539	29332	29925	30718	
HA800	R1	5840	6010	6190	6360	6530	6700	4980	5100	5220	5330	5450	5570	5680	5800	5910	6030
	R2	5170	5330	5500	5660	5830	6000	4210	4320	4430	4540	4650	4760	4870	4980	5090	5200
	R3	9890	10210	10530	10850	11170	11480	8040	8250	8450	8660	8870	9090	9300	9510	9720	9930
	R4	-	-	-	-	-	-	7760	7980	8190	8410	8630	8840	9060	9280	9490	9710
HA1000	R1	6470	6650	6840	7030	7210	7400	5540	5670	5800	5920	6050	6180	6310	6430	6560	6680
	R2	5640	5820	6000	6190	6360	6540	4600	4720	4840	4960	5080	5200	5320	5440	5560	5680
	R3	10800	11150	11500	11840	12190	12540	8770	9000	9230	9460	9690	9920	10150	10380	10610	10840
	R4	-	-	-	-	-	-	8480	8710	8950	9190	9420	9660	9900	10130	10370	10610
HA1200	R1	6960	7160	7370	7570	7770	7970	5990	6130	6270	6410	6550	6680	6820	6960	7090	7230
	R2	6120	6310	6510	6700	6900	7090	4990	5120	5250	5380	5510	5640	5770	5900	6030	6160
	R3	11730	12110	12480	12860	13240	13620	9520	9770	10010	10260	10520	10770	11020	11270	11520	11770
	R4	-	-	-	-	-	-	9210	9470	9720	9980	10240	10500	10760	11010	11270	11530

Note: When maximum vertical rise ranges over 15000 mm, consult Hyundai.

Moving Walks

PM-BT

Horizontal Type

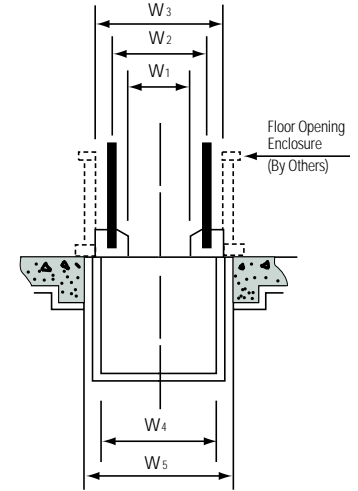
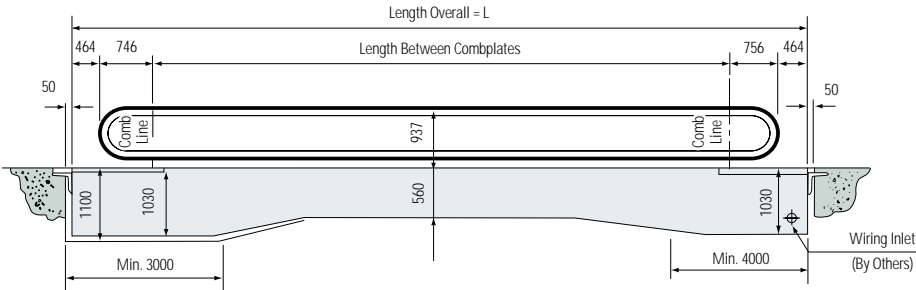

Horizontal & Inclined Type

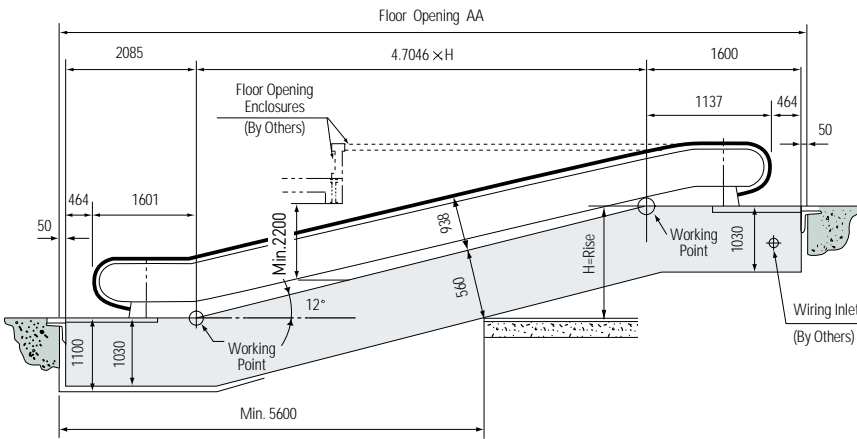

Section Dimensions

(Unit : mm)

Type	PM1000	PM1200
W ₁	800	1000
W ₂	1037	1237
W ₃	1340	1540
W ₄	1300	1500
W ₅	1400	1600

Compact Type

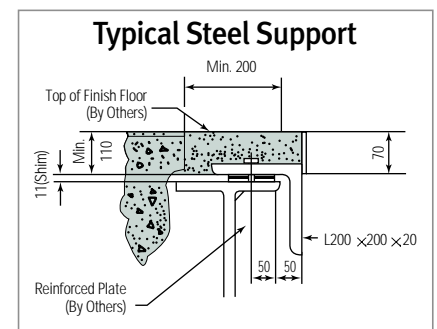
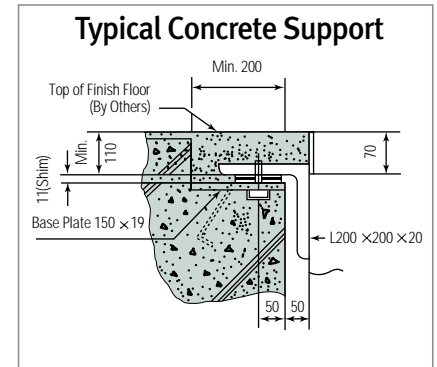
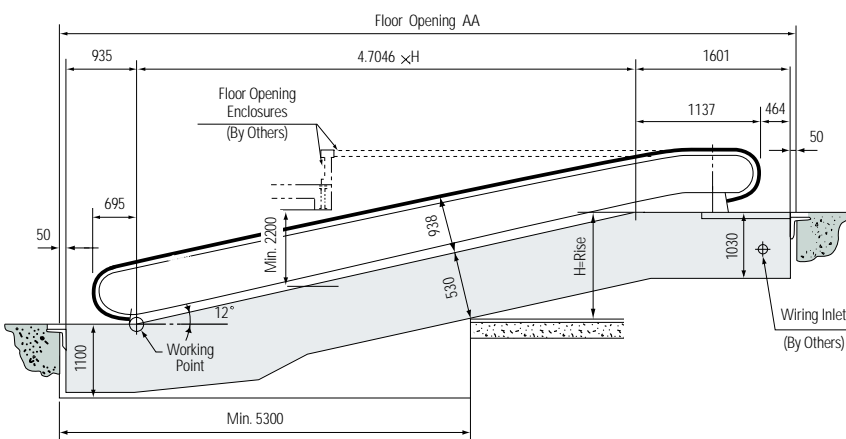

- Notes : 1. When the intermediate supports are required, please consult Hyundai for the intermediate support data.
2. Consult Hyundai if the isolation pad is applied.

Electric Power Requirements (by Others)

There are some building and electrical work which is necessary for a normal escalator installation, but is not done by the escalator contractor. Please consult Hyundai for it.

Electric Power

Type	Motor (kW)	Power Supply Capacity(kVA)	Power Supply Voltage (AC-3Phase)	C.B. Rated Current (A)	Power Feeder(mm ²) (from power room to escalator controller)					
					20m	40m	60m	80m	100m	120m
Wordclass & Modular	5.5	12	I	50	10	16	25	35	35	35
			II	30	6	6	10	16	16	16
			III	30	6	6	6	10	10	16
	7.5	14	I	60	10	25	35	35	50	50
			II	40	6	6	10	16	16	25
			III	30	6	6	6	10	16	16
	5.5 x2/11	19	I	75	16	25	35	35	50	70
			II	50	6	10	16	25	25	25
			III	40	6	6	10	16	16	25
	7.5 x2	27	I	125	25	35	50	95	95	120
			II	75	6	16	25	25	35	35
			III	60	6	10	16	25	25	25
	7.5 x3	40	I	175	35	50	50	120	120	150
			II	100	10	25	35	35	50	50
			III	100	6	16	25	25	35	35
	7.5 x4	52	I	225	35	95	120	120	185	185
			II	150	16	25	35	50	70	95
			III	125	10	25	25	35	35	50
7.5 x5	65	I	300	50	95	120	185	185	240	
		II	175	16	35	50	70	95	95	
		III	150	16	25	35	35	50	70	
7.5 x6	78	I	350	50	120	150	185	240	300	
		II	200	25	35	50	95	95	120	
		III	175	16	25	35	50	70	95	
H-Series	11	19	I	100	16	25	35	50	50	95
			II	50	6	10	16	25	25	25
			III	40	6	6	10	16	16	25
	16	25	I	125	25	35	50	70	95	120
			II	60	6	16	25	25	35	35
			III	50	6	10	16	16	25	25
	18.5	31	I	150	25	35	50	95	120	120
			II	75	10	16	25	35	35	35
			III	75	6	16	16	25	25	35
	22	36	I	175	25	50	95	120	120	150
			II	100	10	16	25	35	35	50
			III	75	6	16	25	25	35	35
26	40	I	175	35	50	95	120	120	150	
		II	125	16	25	35	35	50	50	
		III	100	6	16	25	25	35	35	

Lighting Power

Balustrade Type	Vertical Rise (m)	Power Supply Capacity (kVA)	Power Supply Voltage (AC-1phase)	C.B. Rated Current (A)	Power Feeder(mm ²)					
					20m	40m	60m	80m	100m	120m
With Handrail Lighting (BTL Type)	1.83-4.27	1.4(3)	100-110	30(40)	6	10	16			
	4.28-7.6	2(6)		40(70)	6	10	16	25		
	1.83-4.27	1.4(3)	200-265	20	4		6	10		
	4.28-7.6	2(6)		20(40)	4		6	10		
Without Handrail Lighting	—	1.2	100-110	20	2.5	4	6		10	
			200-265		2.5	4	6		10	

I	3 Ø, 200V, 50Hz	3 Ø, 220V, 60Hz
II	3 Ø, 346V, 50Hz	3 Ø, 380V, 60Hz
III	3 Ø, 415V, 50Hz	3 Ø, 460V, 60Hz

Notes : 1. Consult Hyundai when the rise over 7600 mm.
2. The capacity shown by () mark shall be applied to moving walks.



HYUNDAI ELEVATOR CO., LTD.

HEAD OFFICE & FACTORY

San 136-1, Ami-ri, Bubal-eup, Icheon-si, Gyeonggi-do 467-734, Korea
Tel : 82-31-644-5160 Fax: 82-2-745-4227
Homepage : <http://www.hyundaelevator.co.kr>
E-mail : e-biz@hyundaelevator.co.kr

SEOUL OFFICE (INT'L SALES DIV.)

1-83 Dong-sung-dong, Jongno-gu, Seoul 110-510, Korea
Tel: 82-2-3670-0659 Fax: 82-2-3672-8763-4

■ HYUNDAI ELEVATOR INTERNATIONAL SALES & SERVICE NETWORK

PHILIPPINES

Hyco Industrial Sales Corp.
#81 Kapilligan Cor. Bayani St., Brgy.
Dona Imelda, Quezon City, Philippines
Tel: 63-2-716-0905 Fax: 63-2-714-8896

INDONESIA

PT. Superhelindo Jaya
JL. KH. Moch. Mansyur No 19B,
Jakarta 10140, Indonesia
Tel: 62-21-631-8444 Fax: 62-21-632-6288

THAILAND

Loxley Public Co., Ltd.
Construction Materials Department
102 Na Ranong Rd. Klongtoey,
Bangkok 10110, Thailand
Tel: 66-2-348-8000 Fax: 66-2-240-3127/3128

BANGLADESH

Regional Traders Ltd.
Karim Chamber(3rd Floor)99,
Motijheel Commercial Area
Dhaka-1000, Bangladesh
Tel: 880-2-956-3122 Fax: 880-2-956-7377

INDIA

Kinetic Escalator & Elevator Ltd.
G-92, D-III Block, Midc, Chinchwad, Pune-411.019 India
Tel: 91-20-3950-2190-1 Fax: 91-20-2747-0568

PAKISTAN

Islamabad Industrial & Trading Corp.
205 Amber Estate Shakra-e-faisal,
Karachi - 75350, Pakistan
Tel: 92-21-432-0601-5 Fax: 92-21-432-0617

EGYPT

International Eng. & Trade
10 El Hakam St., Helmeyt El Zayton Cairo, Egypt
Tel: 20-2-2241-8542 Fax: 20-2-2639-2672

U.A.E.

Arabian Elevators & Engineering Co., Ltd.
P. O. Box : 26031, Sharjah, U.A.E.
Tel: 971-6-573-9920 Fax: 971-6-573-0962

KUWAIT

Deal General Trading & Contracting Co.
P. O. Box 27956 Safat, 13140 Kuwait
Tel: 965-245-7925 Fax: 965-242-3510

JORDAN

Bseiso Engineering Materials Corp.
P. O. Box 830681 Amman 11183, Jordan
Tel: 962-656-99012 Fax: 962-656-99014

IRAN

Mehfakhr
Flat No. 84 8th Flr. No. 23 Corner of 13th St.
Asadabadi Ave. Tehran Iran
Tel: 98-21-872-6082 Fax: 98-21-855-3741

SAUDI ARABIA

ETA-Electromechanical & Technical Associates,
Al Murjan Tower, 11th Floor, Suite #1104,
Hail Street and Waly Al Ahd Street Intersection,
P. O. Box 6591, Jeddah-21452, Saudi Arabia
Tel: 966-2-652-9000 Fax: 966-2-652-9090

QATAR

International Eng. & Trade Group Co.
P. O. Box NO.22549 Doha, Qatar
Tel: 97-4-436-6689 Fax: 97-4-556-8842

ALGERI

Flash Engineering & Trade
03 Rue Saidi Ahmed-Bordj El Kiffan Palace Center, Alger, Algeri
Tel: 213-21-203785 Fax: 213-21-216444

TUNISIA

Ascenseurs Leverage & Manutention(ALM)
Rue Abderrahmen Ibn Auof Cite Uv4 Bloc 49-1004 Menzeh 6 tunis - Tunisie
Tel: 216-71-236-373 Fax: 216-71-754-361

PANAMA

Elevadores De Panama S.A.
Via Ricardo J. Alfaro, Diagonal Hospital S.M. Arcangel Republic of Panama
Tel: 507-230-3166 Fax: 507-230-3187

GUATEMALA

Elevadores Otis S.A. De C.V.
17 Calle 14-53 Zona 13 Guatemala City, Guatemala
Tel: 502-2381-7600 Fax: 502-2381-7676

CHINA

* Shanghai Hyundai Elevator Manufacturing Co., Ltd.

• Head Office(Factory)
Zhenxi Nanlu No.182, Liantang Zhen, Qingpu Xian,
Shanghai China 201716
Tel: 86-21-5981-3981/3990/3961/3971 Fax: 86-21-5981-3982

• Shanghai Office
27F, Jinxuan Bldg., No.238 Nandan Rd(East),
Shanghai, China, 200030
Tel: 86-21-6427-6616/9569 Fax: 86-21-6427-4428